

BESA HIU Test Report

VVX-IV 2-1 U UFH

Modules Tested: 2 & 8

Client: Gemina Termix

Project Number: E5163 Report Issue: 5

02 June 2026

Prepared By:



Jack Scargill – Project Engineer

Approved By:



Simon Broxham – Operations Manager



THIS PAGE IS INTENTIONALLY LEFT BLANK

DISCLAIMER

This report is confidential to the client named on the front cover.

This report may be stored, transmitted, or reproduced in full by the named client, however if the report is to be placed in the public domain or used for publicity / promotional purposes please inform a director of Enertek International Ltd.

The report must not be reproduced in part, edited, abridged or any extracts used for any purpose whatsoever without written permission from a director of Enertek International Ltd.

The client remains responsible for any data supplied by the client for use in this report. If this data could affect the test results this will be noted in the report.

Any test results contained in this report apply only to the specific sample(s) tested as described in the report.

This report does not imply or indicate any element of commercial approval, recommendation, or promotion by Enertek International Ltd.

Enertek' s default decision rule is in accordance with ILAC-G8:09/2019 simple acceptance.

CONTENTS

1	EXECUTIVE SUMMARY	7
2	BRIEF.....	8
3	DEFINITIONS.....	9
4	INTRODUCTION	12
	4.1 Installation of Appliance	12
	4.2 Appliance Details	12
	4.3 Appliance Design Pressures and Temperatures	12
5	TEST METHOD	13
	5.1 Test Regime.....	13
6	TEST MODULE 2 – SPACE HEATING, LOW TEMPERATURE, DH55 INDIRECT	15
	6.1 Test Module 2 Information.....	15
	6.2 Test Module 2 Results.....	15
7	TEST MODULE 8 – DHW, LOW TEMPERATURE, DH55-KWARM.....	20
	7.1 Test Module 8 Information.....	20
	7.2 Test 11b Information	20
	7.3 Test 11b Results.....	21
	7.4 Test 12b / 12d Information.....	23
	7.5 Test 12b / 12d Results.....	23
	7.6 Test 13b Information	27
	7.7 Test 13b Results.....	27
	7.8 Test 21b Information	30
	7.9 Test 21b Results.....	30
	7.10 Test 22b Information.....	33
	7.11 Test 22b Results.....	33
8	CONCLUSIONS	35
9	EQUIPMENT AND INSTRUMENT LIST	36
10	APPENDIX A.....	37
	10.1 VWART Calculations for Modules 2 & 8	37
11	APPENDIX B.....	38
	11.1 Appliance Documentation.....	38
	11.2 Appliance Photographs	40
12	APPENDIX C.....	43
	12.1 UK Declaration of Conformity	43
	12.2 Water Regulation 4 Certificate.....	44
13	BIBLIOGRAPHY	46

List of Figures

Figure 1 - EIL’s HIU Test Rig Schematic which is taken from Appendix B, Figure 4, of Technical Standard for UK HIU Test Regime V3-Rev002: March 2026	14
Figure 2 - Test 01d Key Metrics.....	17
Figure 3 - Test 01e Key Metrics.....	18
Figure 4 - Test 01f Key Metrics	19
Figure 5 - Test 11b Key Metrics.....	22
Figure 6 - Test 12b Key Metrics.....	25
Figure 7 - Test 12d Key Metrics.....	26
Figure 8 - Test 13b Key Metrics.....	29
Figure 9 - Test 21b Key Metrics.....	32
Figure 10 - Test 22b Key Metrics.....	34
Figure 11 - HIU with Outer Case Fitted	40
Figure 12 - HIU with Outer Case Removed	41
Figure 13 - Nameplate with Model Details and Serial Number	42
Figure 14 - UK Declaration of Conformity.....	43
Figure 15 - Water Reg 4 Certification - Page 1.....	44
Figure 16 - Water Reg 4 Certification – Page 2	45

List of Tables

Table 1 - Appliance Details and Modules Tested.....	7
Table 2 - Modules Tested Pass or Fail Summary.....	7
Table 3 - Modules 2 & 8 VWART Information.....	7
Table 4 - Definitions and Abbreviations.....	9
Table 5 - Appliance Details.....	12
Table 6 - Appliance Design Pressures and Temperatures.....	12
Table 7 - Module 2 Tests.....	15
Table 8 - Module 2 Performance Criteria	15
Table 9 - Module 2 Best Practice	16
Table 10 - Module 2 Test Results.....	16
Table 11 - Module 8 Tests.....	20
Table 12 - Module 8 Test 11b Results.....	21
Table 13 - Module 8 Test 11b Performance Criteria.....	21
Table 14 - Module 8 Test 11b Best Practice.....	21
Table 15 - Module 8 Test 12 Results.....	23
Table 16 - Module 8 Test 12 Performance Criteria.....	23
Table 17 - Module 8 Test 12 Best Practice.....	24
Table 18 - Module 8 Test 13b Performance Criteria.....	27
Table 19 - Module 8 Test 13b Results.....	28
Table 20 - Module 8 Test 21b Results.....	30
Table 21 - Module 8 Test 21b Performance Criteria.....	30
Table 22 - Module 8 Test 21b Best Practice.....	31
Table 23 - Module 8 Test 22b Results.....	33
Table 24 - Module 8 Test 22b Performance Criteria.....	33
Table 25 - Module 8 Test 22b Best Practice.....	33
Table 26 - Appliance Documentation	38

1 EXECUTIVE SUMMARY

1.1.1 The VVX-IV 2-1 U UFH HIU underwent testing to the BESA Technical Standard for UK HIU Test Regime, V3-Rev002: March 2026. Modules 2 & 8 were tested. Summary tables can be seen below, with further technical data shown in each respective test module chapter of this report. VWARD calculations can be found within APPENDIX A.

1.1.2 It should be noted that all VWARD figures are to within $\pm 2^{\circ}\text{C}$ tolerance.

1.1.3 Results for Module 8 have been taken from the previous project (E4970).

Table 1 - Appliance Details and Modules Tested

Manufacturer:	Gemina Termix
Model:	VVX-IV 2-1 U UFH
Modules:	2 & 8

Table 2 - Modules Tested Pass or Fail Summary

Module 2:	Pass
Module 8:	Pass

Table 3 - Modules 2 & 8 VWARD Information

	VWARD ($^{\circ}\text{C}$)	Volume (m^3)
DHW	18	44.4
Standby	41	52.5
Space Heating	36	70.2

	VWARD ($^{\circ}\text{C}$)
Summer	31
Winter	33
Overall	32

2 BRIEF

- 2.1.1 EnerTek International Limited (EIL), were contracted to receive, install and commission a production sample of the VVX-IV 2-1 U UFH.
- 2.1.2 To perform the tasks required for assessing the efficiency of Domestic Hot Water (DHW) and Space Heating (SH) as per the BESA Technical Standard for UK HIU Test Regime, V3-Rev002: March 2026, a publicly available online test regime. This is here-on referred to as the Test Regime throughout this document.
- 2.1.3 To provide a report detailing the tests carried out and generated results in accordance with the Test Regime criteria, including calculations for Volume Weighted Average Return Temperatures (VWART).

3 DEFINITIONS

3.1.1 The following definitions and abbreviations which have been used within this report can be found in Table 4 below.

Table 4 - Definitions and Abbreviations

Symbol	Description
t_{10}	Temperature, primary source
t_{11}	Temperature, primary side flow connection
t_{12}	Temperature, primary side return connection
t_{21}	Temperature, space heating system return connection
t_{22}	Temperature, space heating system flow connection
t_{31}	Temperature, cold water supply
t_{32}	Temperature, domestic hot water flow from HIU
t_{b1}	Temperature, primary side bypass flow (for non-keep warm configuration)
t_{b2}	Temperature, primary side bypass return (for non-keep warm configuration)
q_1	Volume flow, primary side
q_2	Volume flow, space heating system
q_3	Volume flow, domestic hot water
P_{11}	Static pressure, primary side flow connection
P_{12}	Static pressure, primary side return connection
P_{21}	Static pressure, space heating system return connection
P_{22}	Static pressure, space heating system flow connection
P_{31}	Static pressure, cold water supply
P_{32}	Static pressure, domestic hot water flow from HIU
dP_1	Differential pressure, primary system across HIU
dP_2	Differential pressure, space heating system across HIU
dP_3	Differential pressure, domestic hot water across HIU
Q_{DHW}	Estimated annual energy demand per year for hot water
Q_{SH}	Estimated annual energy demand per year for space heating
n_{DHW}	Number of DHW events per year

H_1	Arithmetic mean of primary side power recorded during test
H_2	Arithmetic mean of space heating power recorded during test
H_3	Arithmetic mean of DHW power recorded during test
h_{DHW}	Annual hours that HIU is producing DHW
h_{SH}	Annual hours that HIU is producing space heating
h_{KWM}	Annual hours that HIU is in keep warm mode
h_{NKWM}	Annual hours that HIU is in non-keep warm mode
V_{DHW}	Volume of primary water recorded during and post-DHW test
V_{SH}	Volume of primary water recorded during space heating tests
V_{KWM}	Volume of primary water recorded during keep warm test
V_{NKWM}	Volume of primary water recorded during non-keep warm test
$Prop_{Summer}$	Proportion of year HIU is operating in “summer” mode
$Prop_{Winter}$	Proportion of year HIU is operating in “winter” mode
$VWART_{DHW}$	DHW Volume Weighted Average Return Temperature
$VWART_{SH}$	Space Heating Volume Weighted Average Return Temperature
$VWART_{KWM}$	Keep Warm Volume Weighted Average Return Temperature
$VWART_{NKWM}$	Non-Keep Warm Volume Weighted Average Return Temperature
$VWART_{WINTER}$	Annual Volume Weighted Average Return Temperature for Heating Period
$VWART_{SUMMER}$	Annual Volume Weighted Average Return Temperature for Non-Heating Period
$VWART_{HIU}$	Total Annual Volume Weighted Average Return Temperature
$W_{thermal}$	Thermal energy use
$W_{electrical}$	Electrical energy use
SH_{PROP}	Annual heating period
NSH_{PROP}	Annual non-space heating period
TMV	Thermostatic mixing valve
TRV	Temperature regulating valve
UFH	Underfloor heating
DHW	Domestic hot water
HIU	Heat interface unit

DPCV	Differential pressure control valve
DRV	Double regulating valve
SH	Space heating
UKAS	United Kingdom Accreditation Service
EIL	Enertek International Limited

4 INTRODUCTION

4.1 Installation of Appliance

4.1.1 The appliance was installed and commissioned (as received) and as defined in the product literature provided. Testing was carried out without further adjustment other than disabling the internal space heating pump and adjusting the setting of the SH and DHW set points through the user interface on the HIU controller to suit the conditions of the HIU test rig.

4.1.2 The HIU rig schematic is shown within Figure 1.

4.1.3 The HIU was commissioned in accordance with the technical manual / installation guide provided by Gemina Termix. The location of which can be found within the references section of this report.

4.2 Appliance Details

4.2.1 Details of the VVX-IV 2-1 U UFH HIU appliance are given in Table 5. Photographs of the installed appliance are given in Figure 11, Figure 12 and Figure 13.

4.2.2 The UK declaration of conformity (CE or UKCA or equivalent) and water regulation 4 certificate can be found within APPENDIX C.

Table 5 - Appliance Details

Item	Description
Manufacturer	Gemina Termix
Model	VVX-IV 2-1 U UFH
Serial Number	K5806879
Year of Manufacture	2024
DHW Priority	Yes
EUT Number	EUT 0711
Date Test Item Received	05/04/2024

4.3 Appliance Design Pressures and Temperatures

4.3.1 The maximum design pressures and temperatures of the VVX-IV 2-1 U UFH appliance for the primary side and the secondary side for both Space Heating and DHW are given in Table 6.

Table 6 - Appliance Design Pressures and Temperatures

Item	Pressure (bar)	Temperature (°C)	Differential Pressure (bar)
Primary Side	15	99	4.5
Secondary Side Space Heating	2.5	80	2.5
Secondary Side DHW	10	70	6

5 TEST METHOD

5.1 Test Regime

5.1.1 The testing described in this report was carried out in accordance with the test regime. The test regime outlines a series of static and dynamic tests to determine the performance of a HIU's DHW and SH functions. The test regime outlines the test method including the reporting of the results, the performance requirements and the VWART calculations.

5.1.2 Testing was carried out in accordance with Test Module 2.

5.1.3 Testing was carried out in accordance with Test Module 8.

5.2 Measurement & Uncertainties

5.2.1 All measurements and uncertainties adhere to the requirements stipulated in the BESA Test Regime. All measurements were sampled at a rate of 1 Hz for all tests.

5.2.2 The BESA uncertainties of measurement requirements are as follows:

- Differential Pressure, ± 1.0 kPa
- Temperature, ± 0.1 °C
- Volume Flow (≥ 0.06 l/s) ± 1.5 %
- Volume Flow (< 0.06 l/s), ± 3.0 %

Note: the time constant for the temperature sensors is less than 1.5 s. The time constant for the differential pressure sensors is less than 5s.

5.2.3 EIL's reported uncertainty is based on a standard uncertainty by a coverage factor $K=2$, providing a level of confidence of approximately 95%. The uncertainty evaluation has been carried out in accordance with UKAS requirements. The EIL equipment list and uncertainties are given in shown within chapter 9.

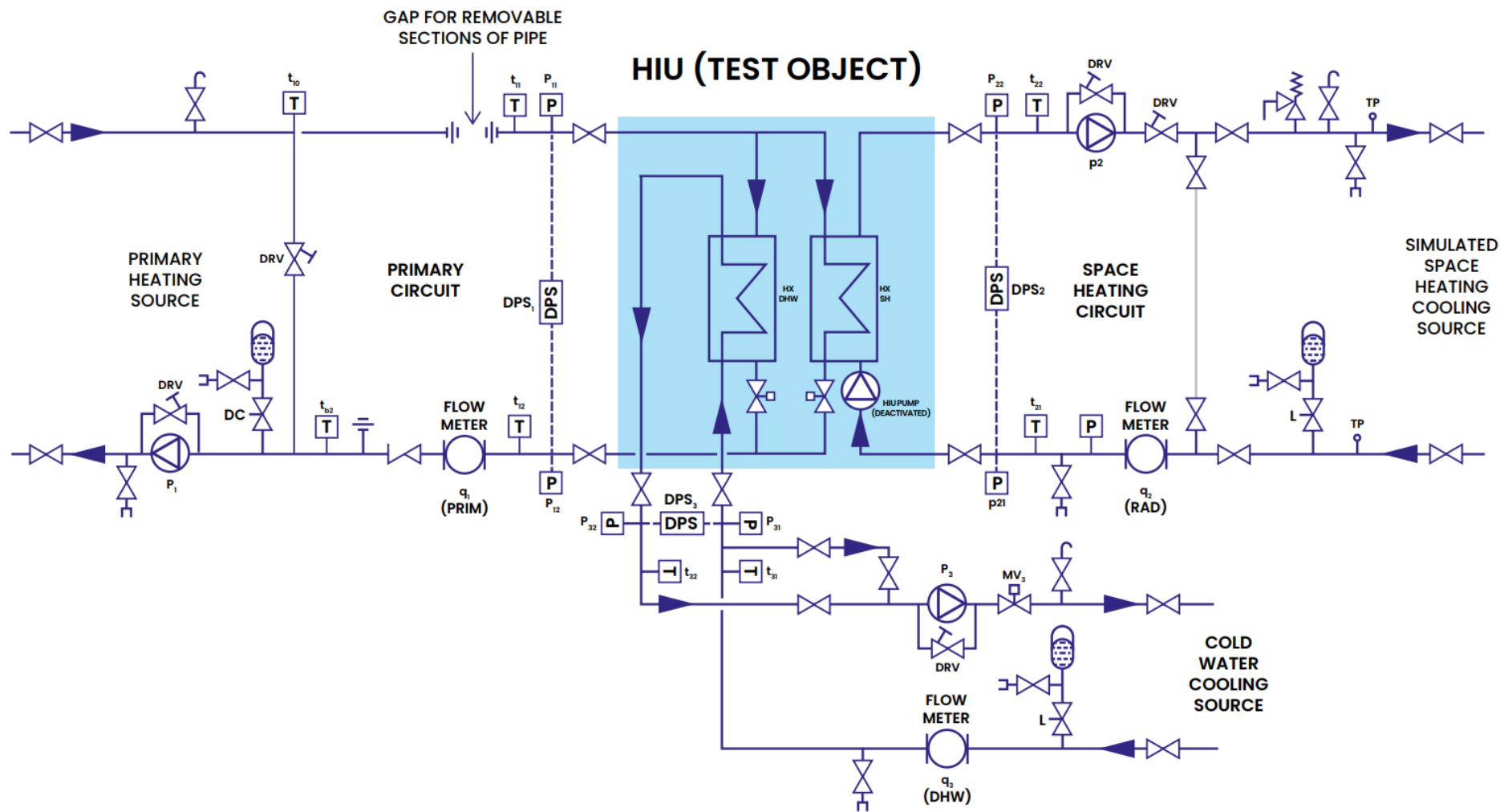

Figure 1 - EIL's HIU Test Rig Schematic which is taken from Appendix B, Figure 4, of Technical Standard for UK HIU Test Regime V3-Rev002: March 2026

6 TEST MODULE 2 – SPACE HEATING, LOW TEMPERATURE, DH55 INDIRECT

6.1 Test Module 2 Information

6.1.1 Objective: Perform static testing to investigate the performance characteristics of the HIU when indirectly meeting a space-heating load given a 45°C/35°C tertiary heating circuit and 55°C primary flow temperature.

6.1.2 The following set of tests are from Test Module 2 - Space Heating, Low Temperature, Indirect Heating Module 2-DH55 Indirect - V1-Rev002:2026.

Table 7 - Module 2 Tests

Module 2 Tests	
01d	DH/55C, Space Heating Indirect 0.5 kW, 45/35°C tertiary, 50 kPa
01e	DH/55C, Space Heating Indirect 1 kW, 45/35°C tertiary, 200 kPa
01f	DH/55C, Space Heating Indirect 4 kW, 45/35°C tertiary, 50 kPa

6.2 Test Module 2 Results

6.2.1 Performance criteria results can be seen in Table 8, test result data can be seen in Table 10 and key metrics can be found in Figure 2, Figure 3 and Figure 4. Best practice criteria can be found in Table 14.

Table 8 - Module 2 Performance Criteria

Module 2 Tests Performance Criteria	
Performance Criteria, Fail if:	PASS/FAIL
VWART is above 37°C (to one decimal point)	PASS
Space heating flow temperature, t22, is not maintained at 45°C ± 5.0°C (to one decimal place) for more than one second	PASS
Average space heating flow temperature, t22, across the test is not 45°C ±0.5°C (to one decimal place) (01f only)	PASS
Average space heating flow temperature, t22, across the test is not 45°C -0.5°C / +2.0°C (to one decimal place) (01d and 01e)	PASS

Table 9 - Module 2 Best Practice

Module 2 – Best Practice Criteria	
Best Practice Criteria if:	Best Practice
VWART is less than or equal to 36°C (to one decimal point)	Not achieved
Average space heating flow temperature, t ₂₂ , across all three tests is within 45°C ±0.5°C	Not achieved

Table 10 - Module 2 Test Results

Module 2 Test Results				
Parameter	Symbol	01d (0.5kW)	01e (1kW)	01f (4kW)
Temperature, primary side flow connection	t ₁₁ (°C)	54.9	55.1	54.6
Temperature, primary side return connection	t ₁₂ (°C)	36.6	36.2	36.9
Volume flow, primary side	q ₁ (l/s)	0.0080	0.014	0.053
Differential pressure, primary system across HIU	dP ₁ (kPa)	53	200	53
Arithmetic mean of primary side power recorded during test	H ₁ (W)	610.7	1139.1	3924.0
Temperature, space heating system return connection	t ₂₁ (°C)	35.4	34.8	34.9
Temperature, space heating system flow connection	t ₂₂ (°C)	46.1	45.9	45.0
Volume flow, space heating system	q ₂ (l/s)	0.012	0.023	0.095
Differential pressure, space heating system across HIU	dP ₂ (kPa)	4	2	7
Arithmetic mean of Space heating power during test	H ₂ (W)	548.2	1068.3	4008.7
Volume Weighted Avg. Return Temp	VWART (°C)	37	36	37
Overall VWART (°C)		36		

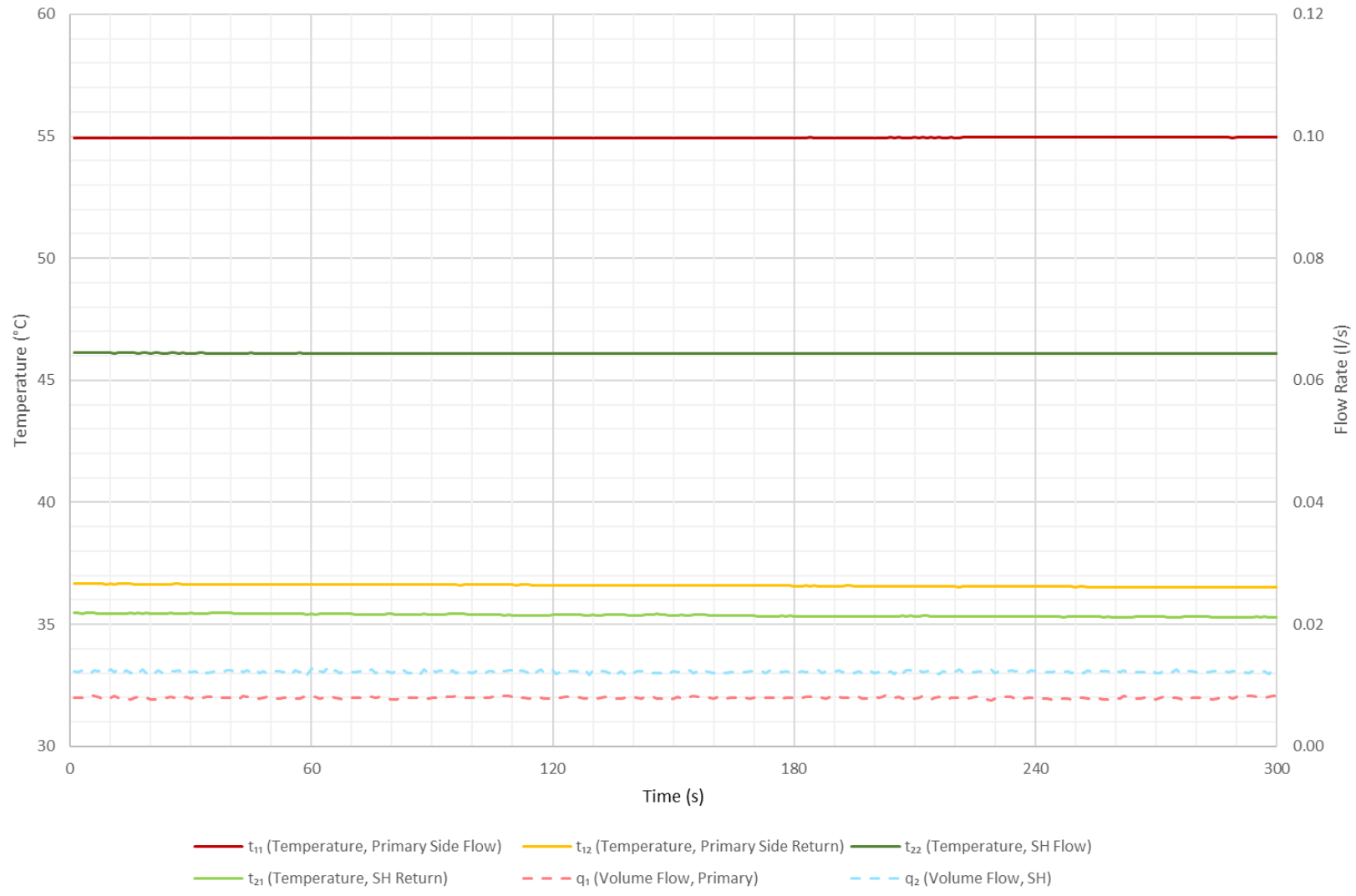

Figure 2 - Test 01d Key Metrics

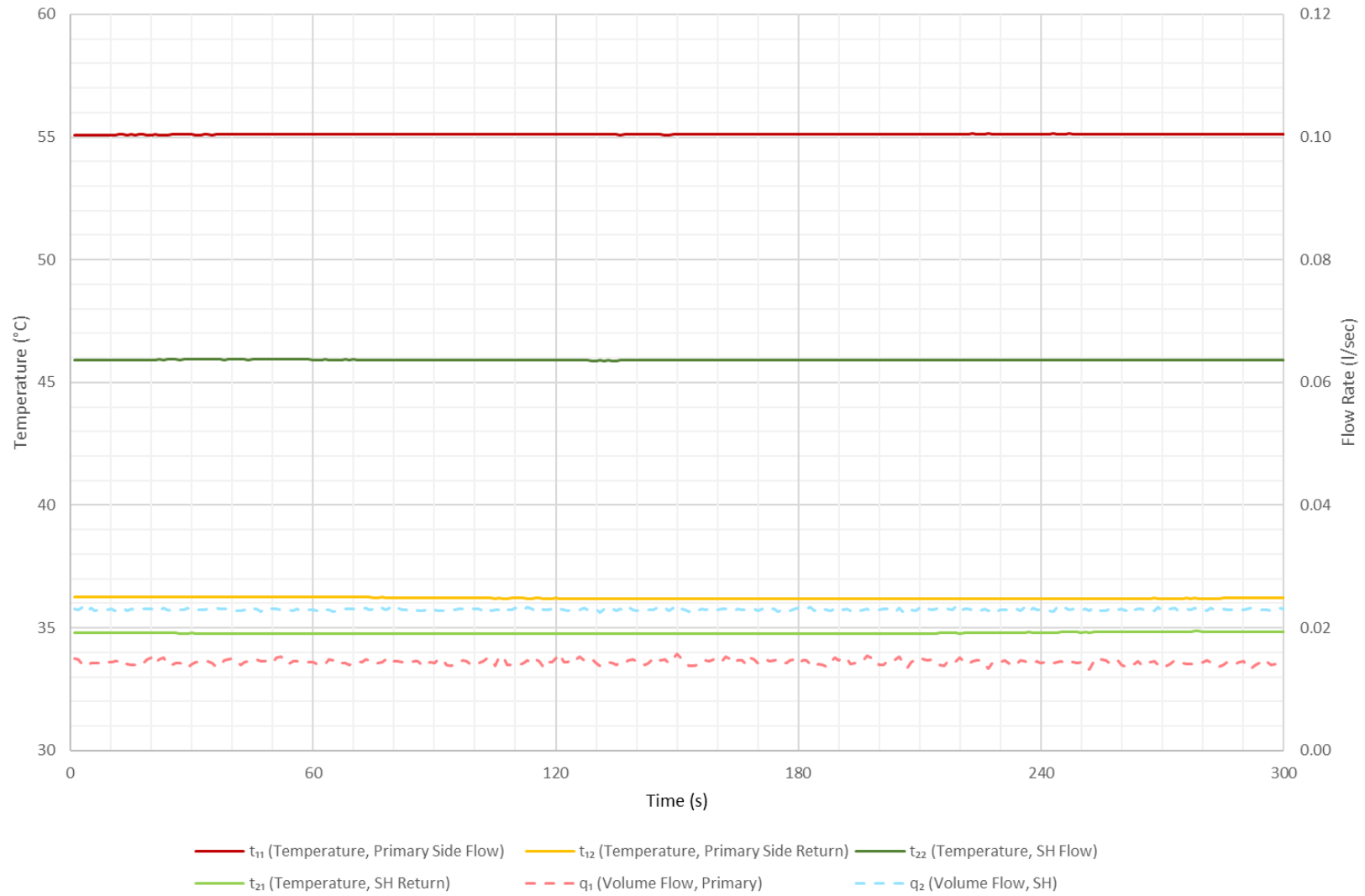

Figure 3 - Test 01e Key Metrics

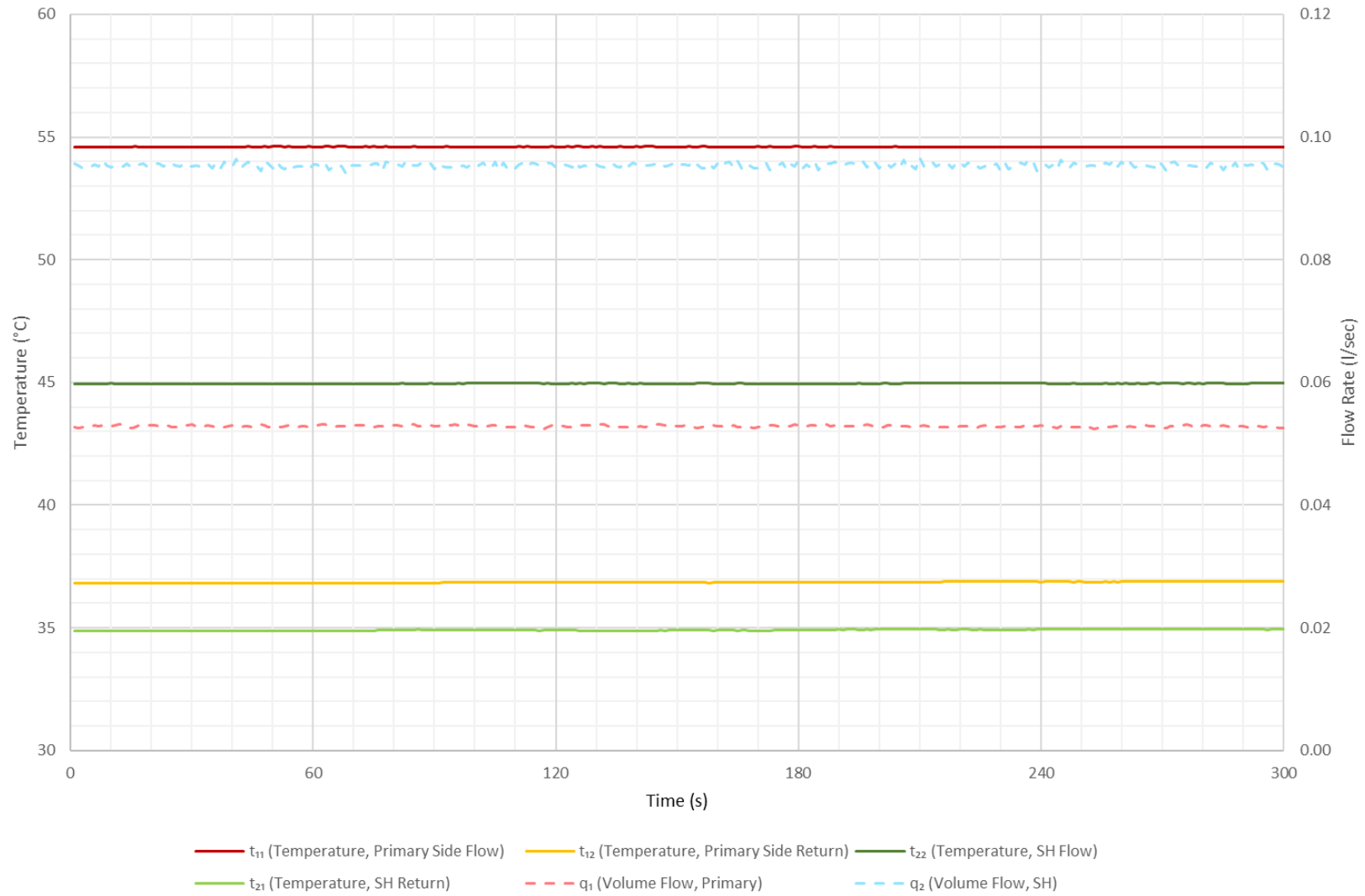

Figure 4 - Test 01f Key Metrics

7 TEST MODULE 8 – DHW, LOW TEMPERATURE, DH55-KWARM

7.1 Test Module 8 Information

7.1.1 Objective: To explore the performance of the HIU under changing loads, as would be the case in practical operation. Key performance criteria are speed and consistency of DHW delivery to the customer; DHW staying at a safe temperature at all times and the volume weighted average return temperature when supplying space heating or DHW.

7.1.2 The following set of tests are from Test Module 8 – Domestic Hot Water, Low Temperature, Keep Warm Hot Water Module 8-DH55-KWarm - V1-Rev002:2026.

Table 11 - Module 8 Tests

Module 8 Tests	
11b	DH/55C, DHW only, 50°C DHW, variable dP
12b	DH/55C, DHW Low Flow, 50°C DHW, 50kPa
12d	DH/55C, DHW Low Flow, 50°C DHW, 200kPa
13b	DH/55C, DHW Load Test, 50°C DHW
21b	DH/55C, DHW Keep Warm, 50°C DHW
22b	DH/55C, DHW Keep Warm Response Time, 50°C DHW

7.2 Test 11b Information

7.2.1 Objective: To investigate the performance of the HIU when delivering DHW, at a range of flow rates and differential pressures, given a 55°C primary flow temperature. The test investigates HIU operation in terms of DHW delivery and impacts on primary heat network return temperatures.

7.3 Test 11b Results

7.3.1 Performance criteria results can be seen in Table 13, test result data can be seen in Table 12 and key metrics can be found in Figure 5. Best practice criteria can be found in Table 14.

Table 12 - Module 8 Test 11b Results

Module 8 - Test 11b Results			
Parameter	Symbol	Result	
Maximum and minimum values of t_{32} when there is DHW flow	t_{32} (°C)	51.6	47.7
Number of consecutive seconds where $t_{32} > 55^{\circ}\text{C}$	(s)	0	
Overall DHW Volume Weighted Avg. Return Temp	VWART (°C)	18	

Table 13 - Module 8 Test 11b Performance Criteria

Module 8 - Test 11b Performance Criteria	
Performance Criteria, Fail if:	PASS/FAIL
DHW temperature (t_{32}) exceeds 60.0°C (to one decimal place) for more than 1 second, as this poses a scalding risk	PASS
Primary return temperature (t_{12}) exceeds 55.0°C (to one decimal place) at any point, as this poses a scaling risk	PASS
VWART is above 25°C (to one decimal place)	PASS
Average DHW temperature (t_{32}) is not $50.0^{\circ}\text{C} \pm 1^{\circ}\text{C}$ (to one decimal place) for the final 150 seconds of each of the 180 second DHW flow periods	PASS
DHW temperature (t_{32}) is not being maintained at $50.0^{\circ}\text{C} \pm 3^{\circ}\text{C}$ (to one decimal place) for >150 seconds of each of the DHW flow periods	PASS
DHW temperature (t_{32}) drops below 45.0°C (to one decimal place) for more than 5 consecutive seconds, as this would impact resident comfort	PASS

Table 14 - Module 8 Test 11b Best Practice

Module 8 – Test 11b – Best Practice Criteria	
Best Practice Criteria if:	Best Practice
VWART is less than or equal to 19°C (to one decimal place)	Achieved
DHW temperature (t_{32}) is being maintained at $50.0^{\circ}\text{C} \pm 2^{\circ}\text{C}$ throughout periods of DHW flow	Not achieved
DHW temperature (t_{32}) doesn't drop below 45.0°C (to one decimal place) for more than 2 consecutive seconds	Achieved

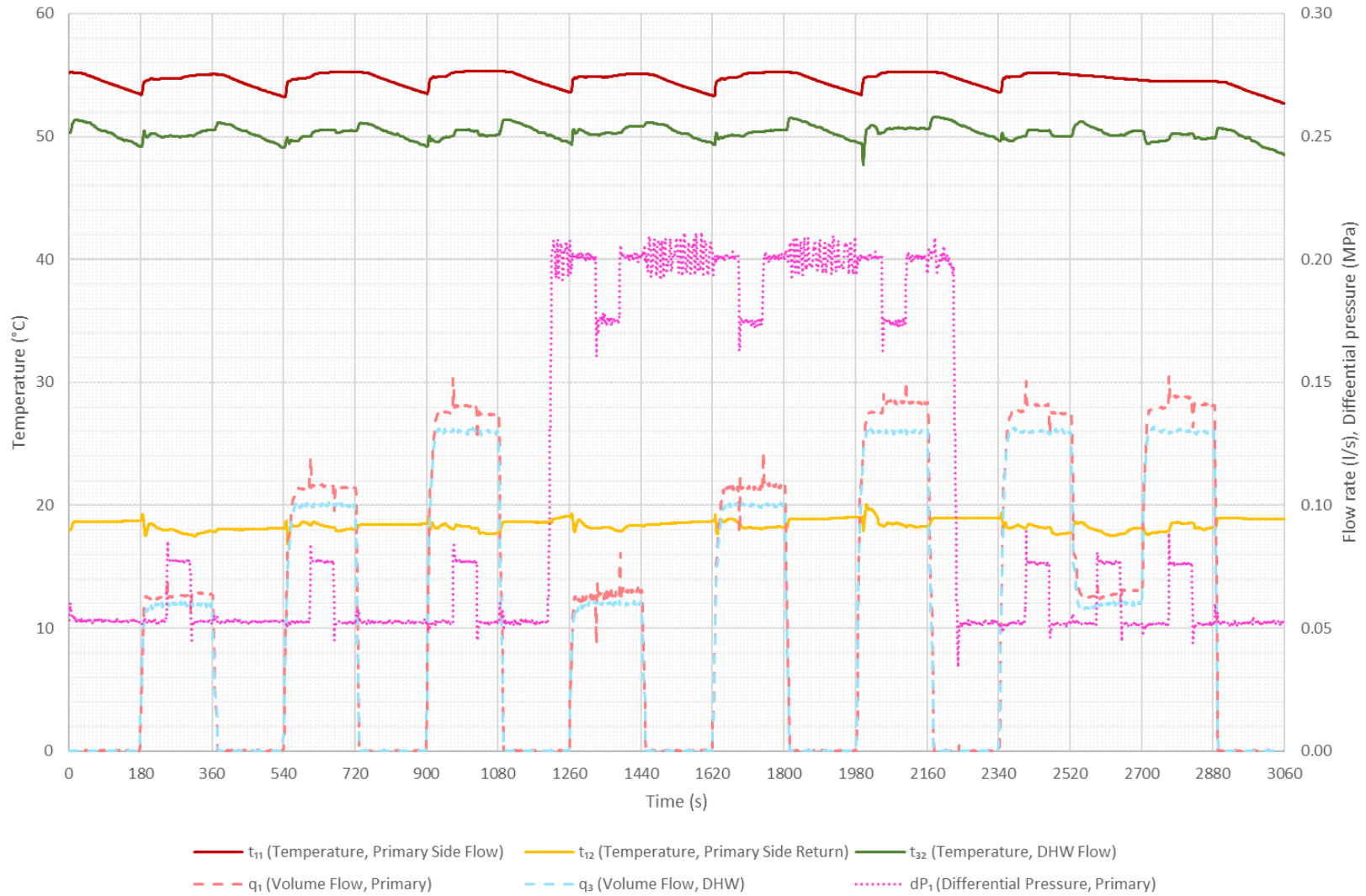

Figure 5 - Test 11b Key Metrics

7.4 Test 12b / 12d Information

- 7.4.1 Objective: To investigate the stability of DHW temperature at low flow rates. During operation, domestic hot water is sometimes drawn off at extremely low flow rates. Test 12 investigates the ability of the system to meet this condition by measuring the temperature at test point t_{32} at a flow rate of 0.02 l/s.
- 7.4.2 Test 12b performs the low flow test at 50kPa differential pressure
- 7.4.3 Test 12d performs the low flow test at 200kPa differential pressure

7.5 Test 12b / 12d Results

- 7.5.1 The HIU was able to deliver DHW at low flow rate above 45.0°C at the end of the 180 second period of low flow DHW.
- 7.5.2 The HIU was able to deliver stable DHW flow temperature (at t_{32}), defined as ability to maintain 50.0 ±3.0°C (1 decimal place) during the last 60 seconds of the test.
- 7.5.3 Performance criteria results can be seen in Table 16, test result data can be seen in Table 15 and key metrics can be found in Figure 6 and Figure 7. Best practice criteria can be found in Table 17.

Table 15 - Module 8 Test 12 Results

Module 8 - Test 12 Results					
Parameter	Symbol	12b Result		12d Result	
Maximum and minimum values of t_{32} when there is low DHW flow	t_{32} (°C)	52.2	50.2	52.3	50.0
Number of consecutive seconds where $t_{32} > 55^{\circ}\text{C}$	(s)	0		0	

Table 16 - Module 8 Test 12 Performance Criteria

Module 8 - Test 12 Performance Criteria	
Performance Criteria, Fail if:	PASS/FAIL
DHW temperature (t_{32}) exceeds 60.0°C (to one decimal place) for more than 1 second, as this poses a scalding risk	PASS
Primary return temperature (t_{12}) exceeds 55.0°C (to one decimal place) at any point, as this poses a scaling risk	PASS
DHW temperature (t_{32}) is not maintained at 50°C ±3°C (to one decimal place) for more than 60 seconds	PASS

Table 17 - Module 8 Test 12 Best Practice

Module 8 – Test 12 – Best Practice Criteria	
Best Practice Criteria if:	Best Practice
DHW temperature (t32) is maintained at 50°C ±2°C (to one decimal place) throughout the test for both test 12b and 12d	Not achieved

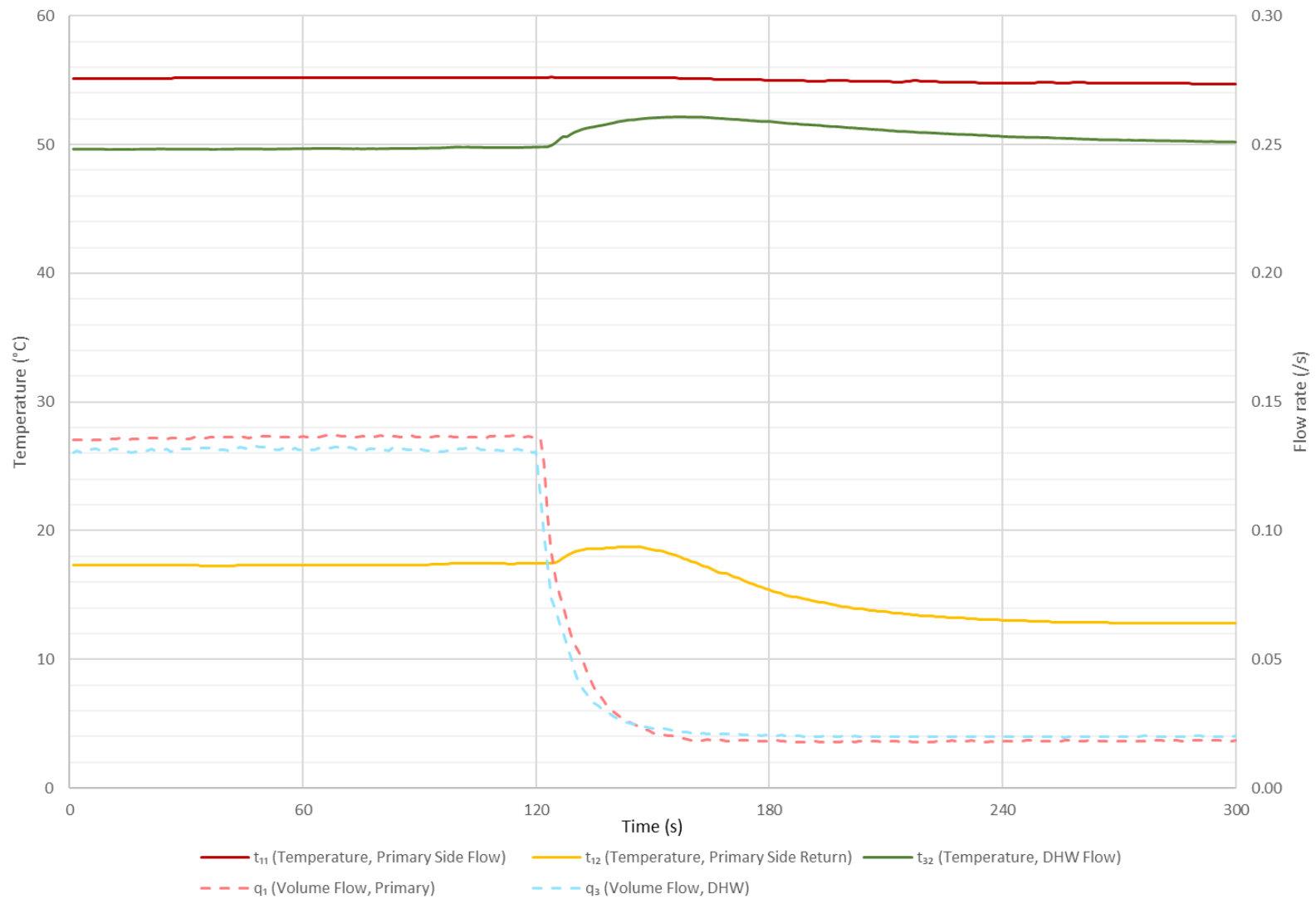

Figure 6 - Test 12b Key Metrics

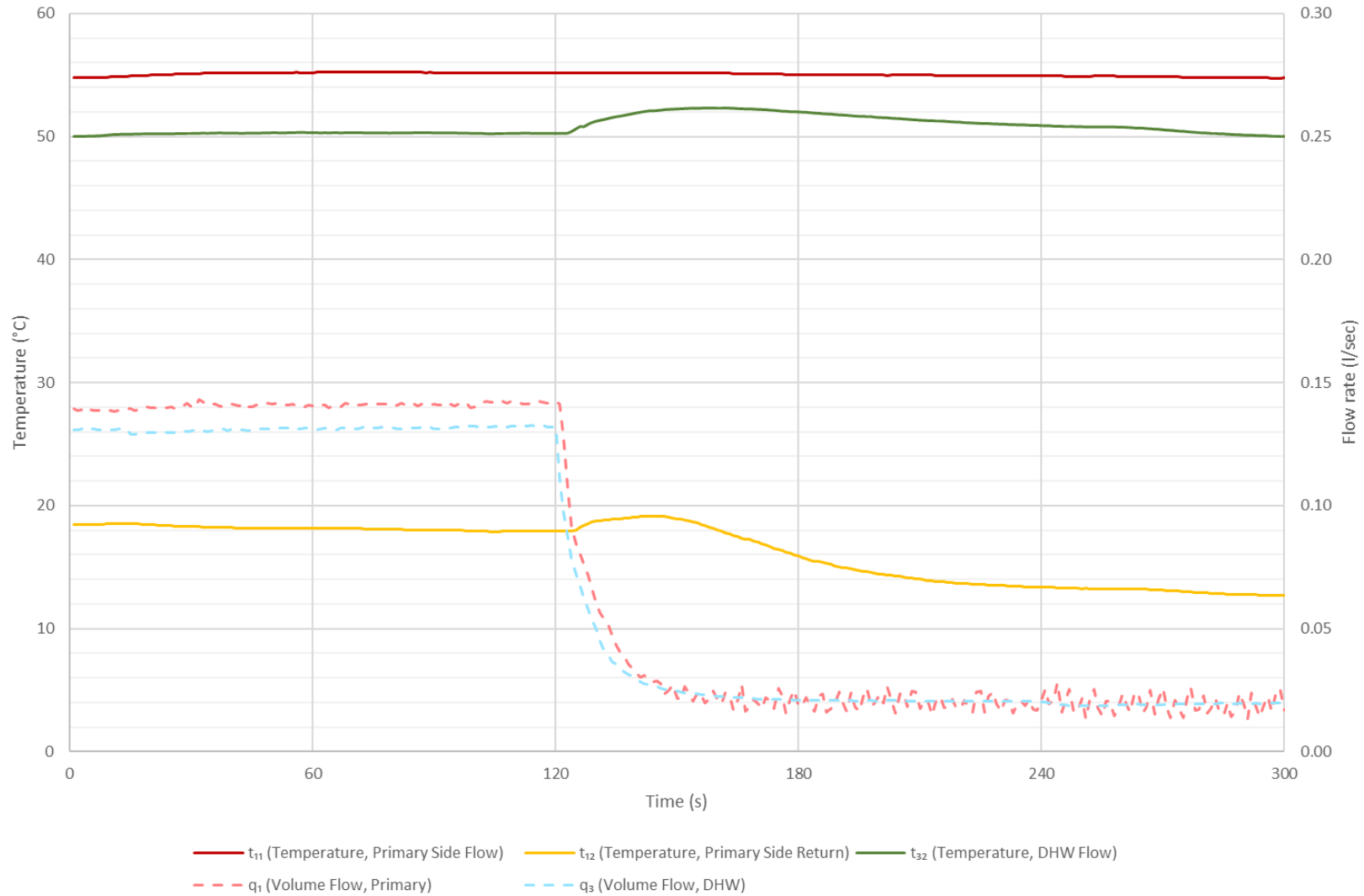

Figure 7 - Test 12d Key Metrics

7.6 Test 13b Information

7.6.1 Objective: To measure the maximum heat output (kW) and flow (l/sec) DHW output that can be delivered from the HIU. The HIU shall be set to deliver 50°C and the maximum DHW power output shall be measured with a flow step change and the peak value recorded when the DHW flow temperature is above 45°C.

7.7 Test 13b Results

7.7.1 The maximum DHW heat output was recorded as 44.7 kW, with a measured flow rate of 0.300 l/s, when producing minimum DHW at 45°C or above. (Temperature achieved at final step 45.0 °C).

7.7.2 The recorded DHW line pressure drop across the HIU was 111 kPa.

7.7.3 The number of consecutive seconds where $t_{32} > 55^{\circ}\text{C}$ was 0 seconds.

7.7.4 Performance criteria results can be seen in Table 18, test result data can be seen in Table 19, key metrics can be found in Figure 8.

Table 18 - Module 8 Test 13b Performance Criteria

Module 8 - Test 13b Performance Criteria	
Performance Criteria, Fail if:	PASS / FAIL
DHW (at t_{32}) is less than $50^{\circ}\text{C} \pm 1.0^{\circ}\text{C}$ (to one decimal place) at 0.13 l/s flow rate, as the HIU must be able to produce DHW to the target temperature at a moderate load	PASS
DHW temperature (t_{32}) exceeds 60.0°C (to one decimal place) for more than 1 second, as this poses a scalding risk	PASS
Primary return temperature (t_{12}) exceeds 55.0°C (to one decimal place) at any point, as this poses a scaling risk	PASS

Table 19 - Module 8 Test 13b Results

Module 8 - Test 13b Results – Mean Average of Last 10 Seconds											
Parameter	Symbol	0.15 l/s (25kW)	0.18 l/s (30kW)	0.21 l/s (35kW)	0.24 l/s (40kW)	0.27 l/s (45kW)	0.30 l/s (50kW)	0.33 l/s (55kW)	0.36 l/s (60kW)	0.39 l/s (65kW)	0.42 l/s (70kW)
Temperature, primary side flow connection	t_{11} (°C)	55.2	55.4	55.4	55.4	55.4	55.4	-	-	-	-
Temperature, primary side return connection	t_{12} (°C)	17.5	17.8	17.0	16.4	15.7	14.5	-	-	-	-
Volume flow, primary side	q_1 (l/s)	0.156	0.189	0.213	0.233	0.248	0.257	-	-	-	-
Arithmetic mean of primary side power recorded during test	H_1 (kW)	24.7	29.7	34.1	38.0	41.2	43.9	-	-	-	-
Temperature, cold water supply	t_{31} (°C)	9.7	9.8	9.4	9.5	9.7	9.3	-	-	-	-
Temperature, domestic hot water flow from HIU	t_{32} (°C)	49.7	49.9	49.0	48.0	46.7	45.0	-	-	-	-
Volume flow, domestic hot water	q_3 (l/s)	0.150	0.180	0.210	0.240	0.270	0.300	-	-	-	-
Differential pressure, domestic hot water across HIU	dP_3 (kPa)	61	70	79	89	100	111	-	-	-	-
Arithmetic mean of DHW power recorded during test	H_3 (kW)	25.1	30.1	34.8	38.6	41.9	44.7	-	-	-	-

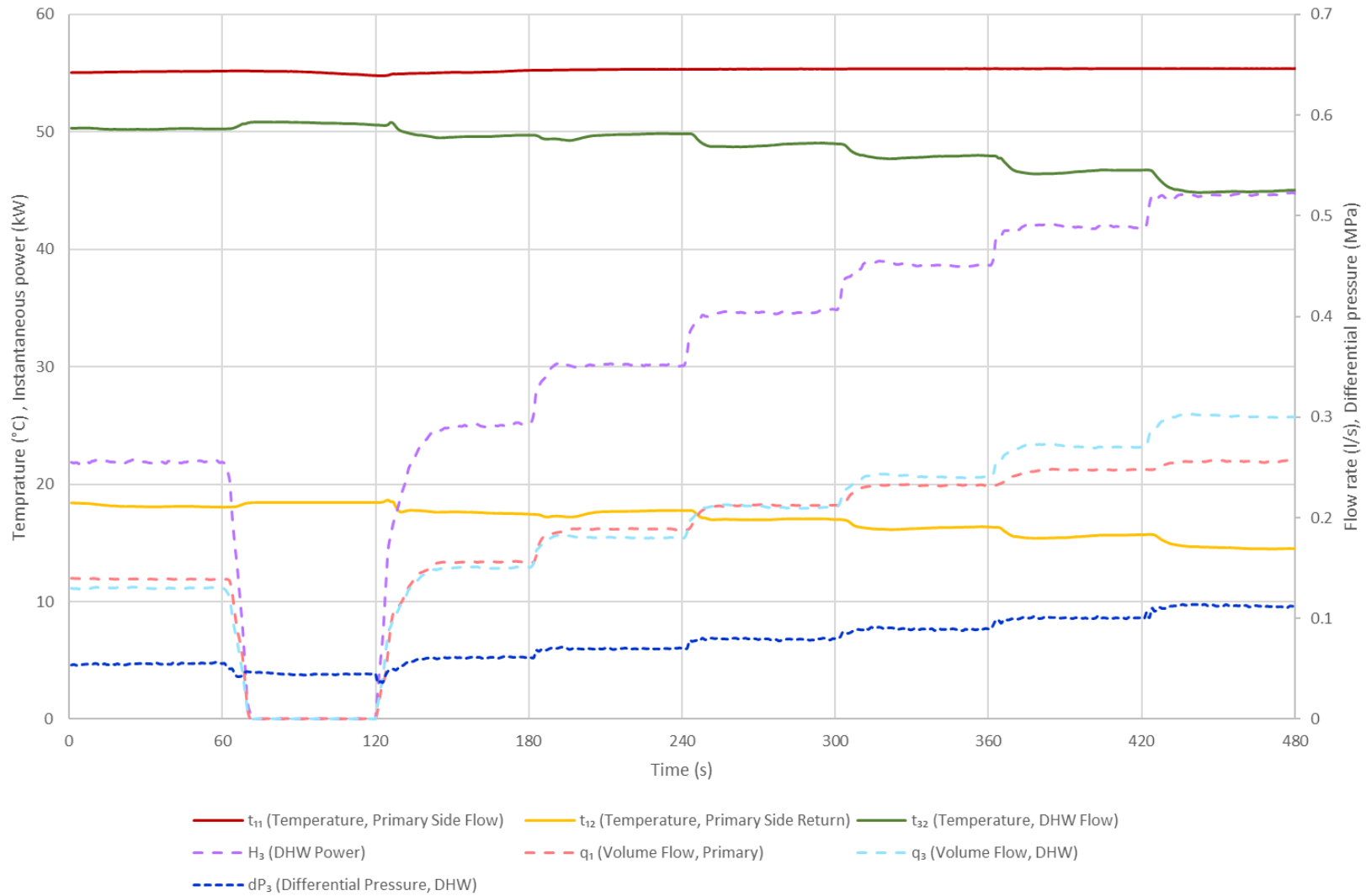

Figure 8 - Test 13b Key Metrics

7.8 Test 21b Information

7.8.1 Objective: To establish HIU performance during periods of no load, when operating in keep warm mode.

7.9 Test 21b Results

7.9.1 The keep warm operation is valid (based on Test 22b response time criteria).

7.9.2 The keep warm does not undergo cycling (i.e. t_{11} varies by more than ± 3 °C during the final 3 hours of the test).

7.9.3 Performance criteria results can be seen in Table 21, test result data can be seen in Table 20 and key metrics can be found in Figure 9. Best practice criteria can be found in Table 22.

Table 20 - Module 8 Test 21b Results

Module 8 - Test 21b Results		
Parameter	Symbol	Result
Mean average volume flow, primary side	q_1 (l/s)	0.0019
Mean average of primary side power recorded during test	H_1 (kW)	0.04
Mean average electrical energy use	$W_{\text{electrical}}$ (W)	0.0
Mean average thermal energy use	W_{thermal} (W)	41.4
Overall energy loss per day	(kWh)	0.995
Overall Keep Warm Volume Weighted Avg. Return Temp	VWART (°C)	41

Table 21 - Module 8 Test 21b Performance Criteria

Module 8 - Test 21b Performance Criteria	
Performance Criteria, Fail if:	PASS/FAIL
VWART is above 48°C (to one decimal place)	PASS
Primary return temperature (t_{12}) exceeds 55.0°C (to one decimal place) at any point, as this poses a scaling risk	PASS
Primary supply temperature to the HIU (t_{11}) drops to below 39°C	PASS
HIU overall energy losses are greater than 1.000 kWh/day (to three decimal places)	PASS
Test 22b DHW temperature response time test fails (i.e. the HIU Keep Warm operation is not a valid Keep Warm)	PASS

Table 22 - Module 8 Test 21b Best Practice

Module 8 – Test 21b – Best Practice Criteria	
Best Practice Criteria if:	Best Practice
HIU overall energy losses are less than or equal to 0.700 kWh/day (to three decimal places)	Not achieved

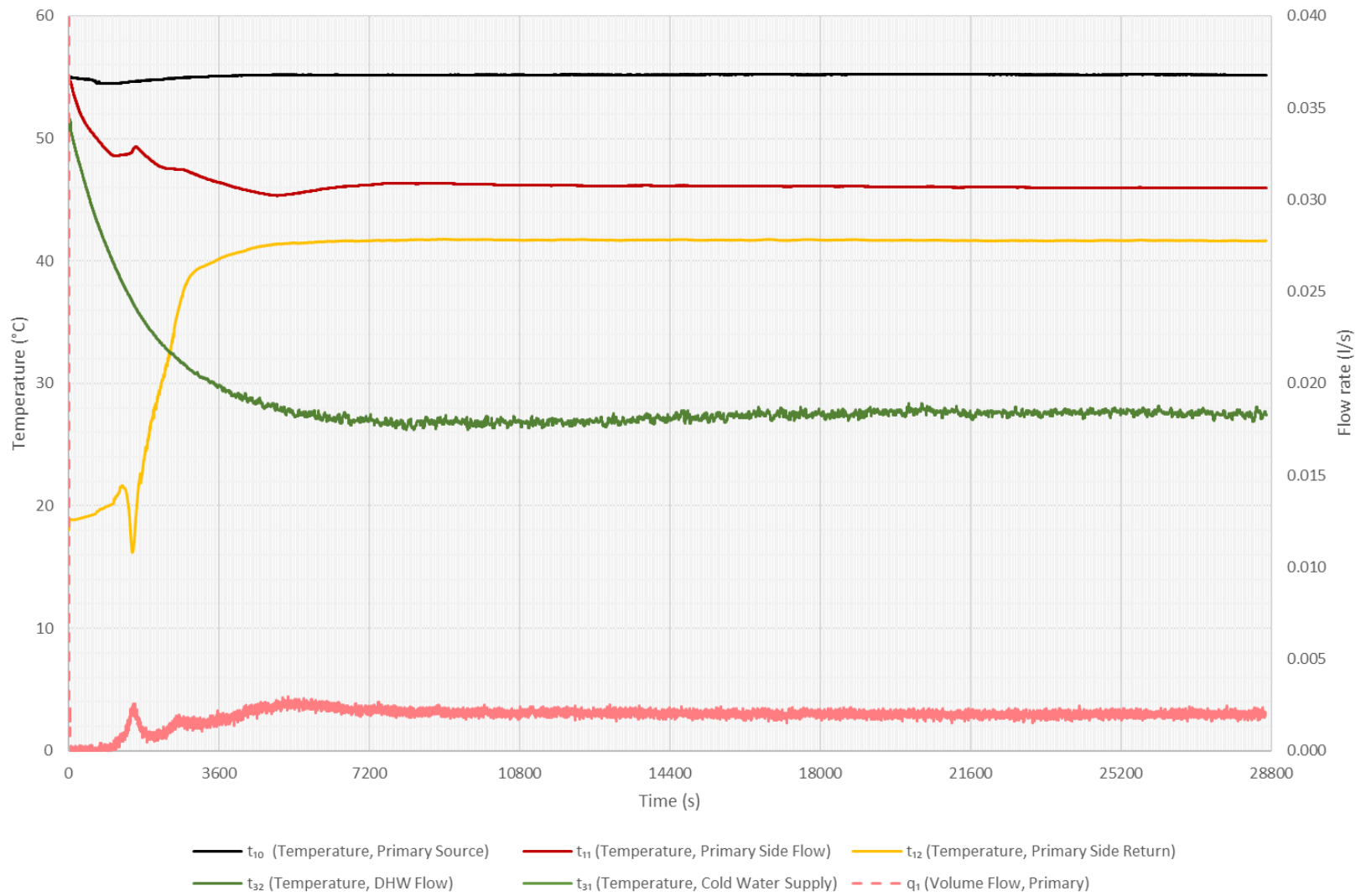

Figure 9 - Test 21b Key Metrics

7.10 Test 22b Information

7.10.1 Objective: To investigate DHW delivery time after a period of at least 8 hours keep warm only operation. This tests if the HIU can supply domestic hot water within an acceptable time of turning on the tap, which is a basic comfort requirement.

7.11 Test 22b Results

7.11.1 The keep warm operation is valid (based on response time criteria shown in Test 22 performance criteria).

7.11.2 Performance criteria results can be seen in Table 24, test result data can be seen in Table 23 and key metrics can be found in Figure 10. Best practice criteria can be found in Table 25.

Table 23 - Module 8 Test 22b Results

Module 8 - Test 22b Results		
Parameter	Symbol	Result
Time taken for t_{32} to reach 45.0°C and not subsequently drop below 42.0°C	(s)	15
Number of consecutive seconds where $t_{32} > 55^\circ\text{C}$	(s)	0
Mean average volume flow, primary side	q_1 (l/s)	0.130

Table 24 - Module 8 Test 22b Performance Criteria

Module 8 - Test 22b Performance Criteria	
Performance Criteria, Fail if:	PASS/FAIL
DHW response time takes more than 15 seconds to reach 45.0°C (to one decimal place) at t_{32} while not dropping below 42.0°C (to one decimal place) thereafter	PASS
DHW temperature (t_{32}) exceeds 60.0°C (to one decimal place) for more than 1 second, as this poses a scalding risk	PASS
Primary return temperature (t_{12}) exceeds 55.0°C (to one decimal place) at any point, as this poses a scaling risk	PASS

Table 25 - Module 8 Test 22b Best Practice

Module 8 – Test 22b – Best Practice Criteria	
Best Practice Criteria if:	Best Practice
DHW response time at t_{32} is less than or equal to 10 seconds	Not achieved

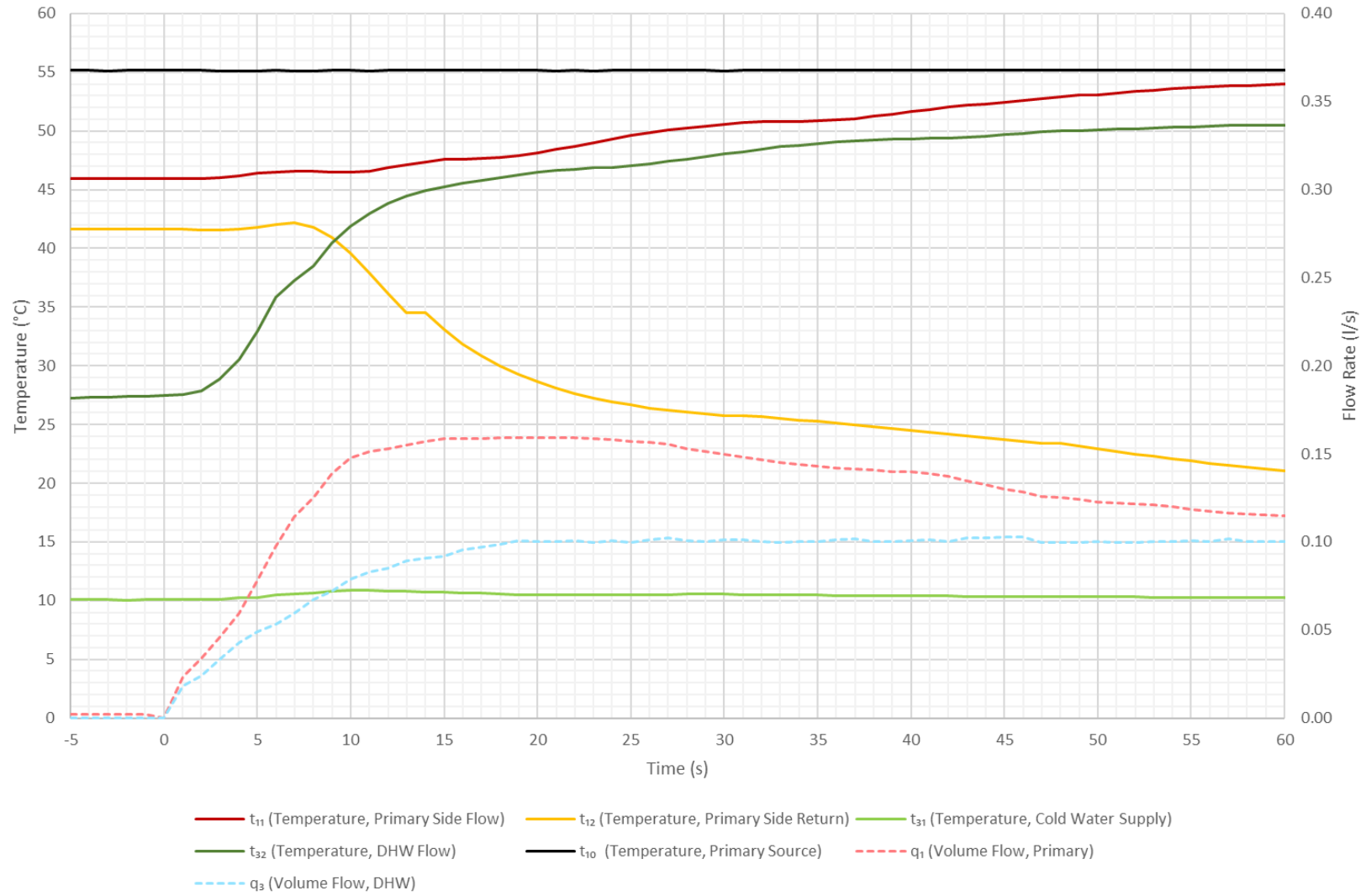

Figure 10 - Test 22b Key Metrics

8 CONCLUSIONS

All conclusions, opinions and interpretations indicated in this report are outside the scope of Enertek's UKAS accreditation.

- 8.1.1 The HIU has passed the requirements of the BESA Technical Standard for UK HIU Test Regime, V3-Rev002: March 2026 – Modules 2 and 8.

9 EQUIPMENT AND INSTRUMENT LIST

EQUIPMENT NAME	ID NUMBER	CERTIFICATE NUMBER	MEASUREMENT UNCERTAINTY K=2	CALIBRATION DATE	CALIBRATION DUE
Cold Water Supply Probe T ₃₁	PRT 5002	CAL 000854	0.073 °C	28/01/2024	01/2025
DHW Outlet Probe T ₃₂	PRT 5003	CAL 000855	0.077 °C	28/01/2024	01/2025
Primary Inlet Probe T ₁₁	PRT 5004	CAL 000856	0.077 °C	28/01/2024	01/2025
Primary Return Probe T ₁₂	PRT 5005	CAL 000857	0.075 °C	28/01/2024	01/2025
SH Flow Probe T ₂₂	PRT 5006	CAL 000858	0.078 °C	28/01/2024	01/2025
SH Return Probe T ₂₁	PRT 5007	CAL 000871	0.077 °C	28/01/2024	01/2025
Primary Flow T ₁₀	PRT 5008	CAL 000872	0.067 °C	28/01/2024	01/2025
Flow Meter	FM 601	K56400FW	0.0135 l/sec	03/09/2023	09/2024
Flow Meter	FM 602	K56401FW	0.0092 l/sec	03/09/2023	09/2024
Flow Meter	FM 603	K56402FW	0.0090 l/sec	03/09/2023	09/2024
Flow Meter	FM 605	K56403FW	0.0035 l/sec	03/09/2023	09/2024
Pressure Transducer	PT 083	K56404P	5.1 kPa	03/09/2023	09/2024
Pressure Transducer	PT 084	K56405P	8.8 kPa	03/09/2023	09/2024
Pressure Transducer	PT 085	K56406P	4.7 kPa	03/09/2023	09/2024
Pressure Transducer	PT 086	K56407P	8.6 kPa	03/09/2023	09/2024
Pressure Transducer	PT 087	K56408P	2.6 kPa	03/09/2023	09/2024
Pressure Transducer	PT 088	K56409P	6.4 kPa	03/09/2023	09/2024
Power Meter	PM 1022	07122	0.09 W	27/08/2023	08/2024
Pipe	PIPE 001	-	-	12/2023	12/2024

The reported expanded uncertainty is based on a standard uncertainty by a coverage factor $K = 2$, providing a level of confidence of approximately 95 %. The uncertainty evaluation has been carried out in accordance with BS EN ISO/IEC 17025:2017 requirements.

10 APPENDIX A

10.1 VWART Calculations for Modules 2 & 8

	VWART (°C)	Volume (m ³)		VWART (°C)
DHW	18	44.4	Summer	31
Standby	41	52.5	Winter	33
Space Heating	36	70.2	Overall	32

	DHW Draw Test Results			Post DHW Draw (60 seconds)	
	Power (W)	Primary Flow (m ³ /hr)	VWART (°C)	Primary Volume (L)	VWART (°C)
Low	9665.7	0.2	18	1.01	18
Medium	15622.2	0.4	18	0.24	19
High	20336.4	0.5	18	0.27	19

DHW Draw Volumes pa		
kWh pa	Hours	Volume pa (m ³)
729	75.42	16.7
297	19.01	7.0
444	21.83	10.4

Post DHW Draw Volumes pa	
Events pa	Volume pa (m ³)
10000	10.149
660	0.159
300	0.081

Standby Test Results	
Primary Flow (m ³ /hr)	VWART (°C)
0.007	41

Standby Volumes pa	
Hours	Volume pa (m ³)
7586	52.516

	Space Heating					
	Power (W)	Primary Flow (m ³ /hr)	VWART (°C)	kWh pa	Hours	Volume pa (m ³)
0.5kW	548	0.029	37	98	179	5.12
1kW	1068	0.052	36	787	737	38.23
4kW	4009	0.190	37	565	141	26.82

10.1.1 It should be noted that all VWART figures are to within $\pm 2^{\circ}\text{C}$ tolerance.

11 APPENDIX B

11.1 Appliance Documentation

11.1.1 The details of the appliance documentation are given in Table 26 below.

Table 26 - Appliance Documentation

#	Component:	Document Submitted (Y/N):	Manufacturer and type:
1	Space Heating Heat Exchanger	Y	Danfoss XB06H-8
2	Domestic Hot Water Heat Exchanger	Y	Danfoss XB06U-40
3	Controller for Space Heating and Hot Water Heating	-	N/A
4	Control Valve and Actuator for Space Heating	Y	Danfoss VMT valve / RAVK sensor
5	Space Heating Strainer	Y	Gemina Termix
6	Control Valve and Actuator for Hot Water Heating	Y	Danfoss IHPT
7	Temperature Sensors	-	N/A
8	Domestic Hot Water Isolating Valve	-	N/A
9	Primary Side Strainer	Y	Gemina Termix
10	Drain Valves	Y	Gemina Termix
11	Vent Valve	Y	Gemina Termix
12	Circulation Pump	Y	Grundfos UPM3
13	Heat Meter	-	N/A
14	Domestic Hot Water Flow Sensor	-	N/A
15	Pipes	Y	ø18 AISI 304 and ø18 AISI 316
16	Connections	Y	¾"
17	Joints	-	N/A
18	Gaskets	Y	Reinz AFM 34
19	O Rings	Y	EPDM
20	Pressure Sensor	-	N/A
21	Expansion Vessel	Y	Cimm
22	Insulation	Y	EPP

A1	Commissioning Guide	Y	Manufacturers operating guide - LGB55001
A2	Operation Guide	Y	Manufacturers operating guide - LGB55001
A3	Declaration of Conformity	Y	See section 12.1
A4	Full Parameter List	-	N/A
A5	Maximum Primary Static Operating Differential Pressure	Y	PN10 Max. Δp 4.5bar
	Software Version	-	N/A
	Model Name and Type Number	Y	VVX-IV 2-1 U UFH
	Serial Number	Y	K5806879
	Any other components stated by manufacturer	Y	<ul style="list-style-type: none"> • FAR shock absorber • Watts safety valve • IMIT thermostat

11.2 Appliance Photographs



Figure 11 - HIU with Outer Case Fitted

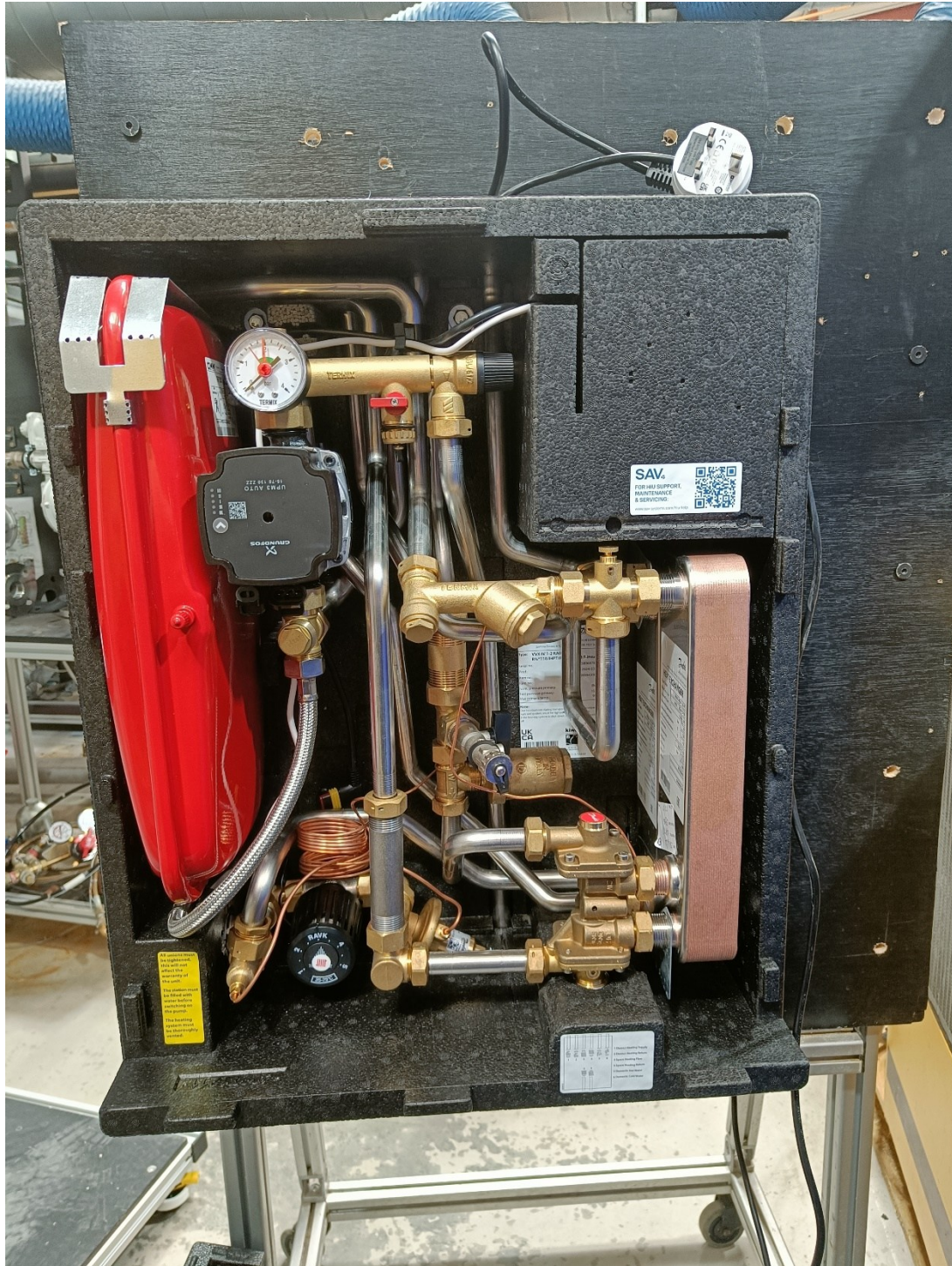

Figure 12 - HIU with Outer Case Removed

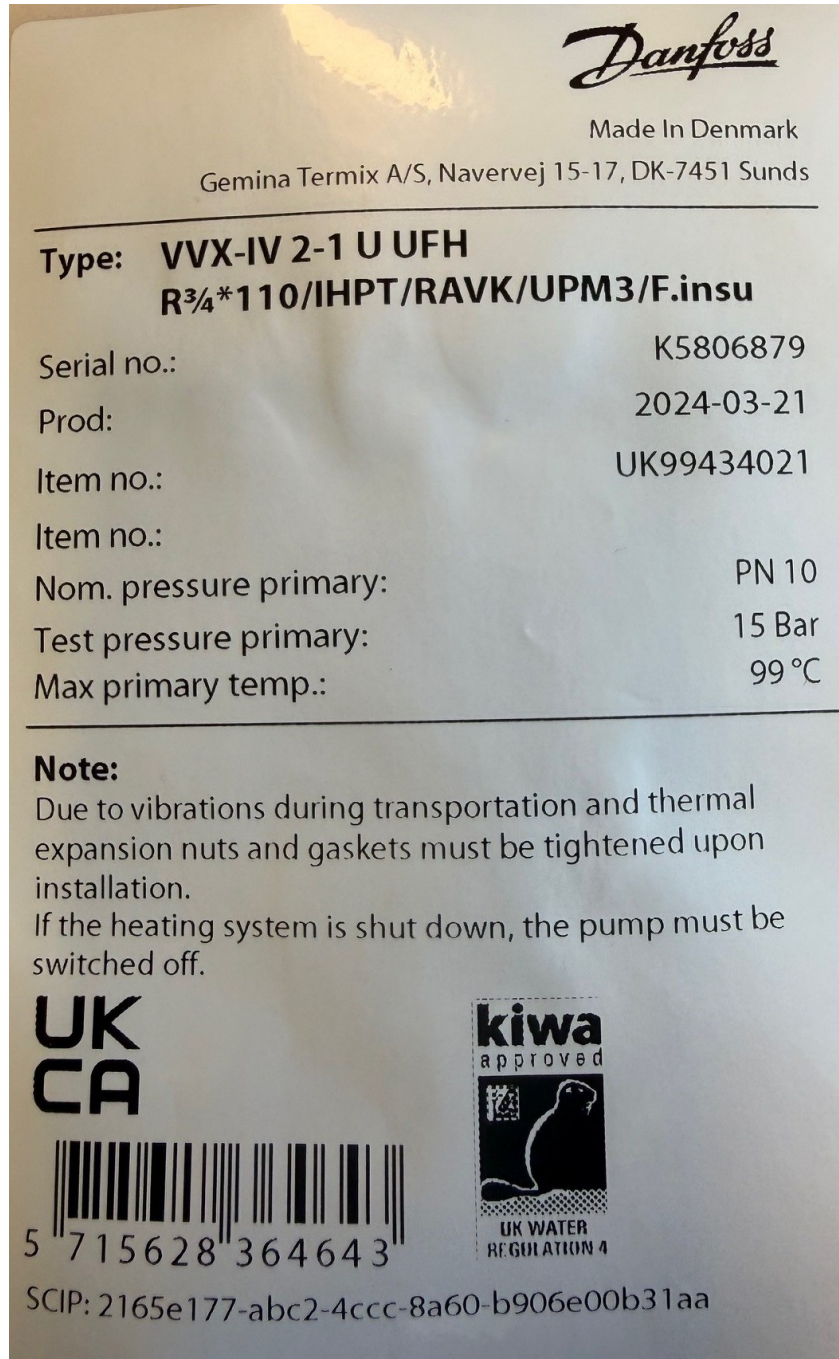

Figure 13 - Nameplate with Model Details and Serial Number

12 APPENDIX C

12.1 UK Declaration of Conformity

 ENGINEERING
 TOMORROW

Danfoss A/S

 6430 Nordborg
 Denmark
 CVR nr.: 20 16 57 15

 Telephone: +45 7488 2222
 Fax: +45 7449 0949

UK DECLARATION OF CONFORMITY

Danfoss A/S
Danfoss District Energy Division

Declares under our sole responsibility that the:

Product category: Small substations

Type designations:

Ø18:	HD	BTD	VMTD mini mix	VX	VVX	One Solar
		BVX	VMTD mix			Mixing loop
			VMTD F mix			Measuring Unit
C28:	CS 28 HD	BV	CS 28 VMTD	CS 28 VX	CS 28 VVX	BL
C32:	CS 32 HD	BV	CS 32 VMTD	CS 32 VX	CS 32 VVX	
C40:		BV	CS 40 VMTD	CS 40 VX	CS 40 VVX	

Covered by this declaration is in conformity with the following directive(s), regulation(s), standard(s) or other normative document(s), provided that the product is used in accordance with our instructions.

Supply of Machinery (Safety) Regulations 2008
BS EN ISO 12100:2011

Safety of machinery – General principles for design – Risk assessment and risk reduction

BS EN 60204-1:2018

Safety of machinery – Electrical equipment of machines – Part 1: General requirements

The Restriction of the Use of Certain Hazardous Substances in Electrical and Electronic Equipment Regulations 2012 (as amended)
BS EN IEC 63000:2018

Technical documentation for the assessment of electrical and electronic products with respect to the restriction of hazardous substances.

Electromagnetic Compatibility Regulations 2016
BS EN 61000-6-1:2007

Electromagnetic compatibility (EMC) – Part 6-1: Generic standards – Immunity residential, commercial and light-industrial environments

BS EN 61000-6-2:2005

Electromagnetic compatibility (EMC) – Part 6-2: Generic standards – Immunity for industrial environments

BS EN 61000-6-3:2007 + A1:2011

Electromagnetic compatibility (EMC) – Part 6-3: Generic standards – Emission standard for residential, commercial and light-industrial environments

Date: 2022.01.13 Place of issue: DK-7451 Sunds	Issued by: <i>Claus G. Mortensen</i> Signature: Name: Claus G. Mortensen Title: Quality Manager	Date: 2022.01.13 Place of issue: DK-7451 Sunds	Approved by: <i>Karina Friis Skov</i> Signature: Name: Karina Friis Skov Title: Director, Engineering
---	---	---	---

Danfoss only vouches for the correctness of the English version of this declaration. In the event of the declaration being translated into any other language, the translator concerned shall be liable for the correctness of the translation

ID No: LUK30022 **Revision No:** 01
 This doc. is managed by 50080577

Page 1 of 1

Figure 14 - UK Declaration of Conformity

12.2 Water Regulation 4 Certificate



CERTIFICATE

Certificate number: 2208704 (1)

Issued 04/08/2022
Expires 04/08/2027

Kiwa Regulation 4 (KUKreg4) Certification

Evaluation Guideline – Kiwa UK – EG004 – Regulation 4(1)(a)
Model number(s) – see Appendix

Danfoss A/S.

Kiwa Watertec declares that legitimate confidence exists in the products specified in this certificate and supplied by the above organisation be relied upon to comply with the Kiwa Evaluation Guideline referred above.

Which verifies the requirements of:

Regulation 4(1)a of the Water Supply (Water Fittings) Regulations 1999 England & Wales: 2009 Northern Ireland and 2014 Byelaws Scotland.

This certificate has been issued in accordance with the Kiwa regulations for product certification.

Signed on behalf of Kiwa Watertec



David Jay, Business Unit Manager – Authorised Signatory
Kiwa Watertec

Publication of this certificate is allowed.

Products are intended to be used in the UK only. For other countries, other (National) requirements will apply.
See <https://www.kiwa.com/gb/en/about-kiwa/water-products/> to ensure that the certificate is still valid.

Kiwa Watertec
(A Trading Division of Kiwa Ltd)
26A Rassau Industrial Estate
Ebbw Vale
Gwent
NP23 5SD
United Kingdom
T +44 (0)1495 308185
uk.water@kiwa.com
www.kiwa.co.uk

Certificate Issued to:
Danfoss A/S
Gemina Termix A/S
Navervej 15-17
DK-7451 Sunds





Product Certificate

Appendix to Certificate number: 2208704

The following products belong to this certificate

PRODUCT DESCRIPTION Range of HIU units. ATS3 – Without Production Surveillance.
MODEL(S) VVX-IV PM10; VVX-IV PN16.
SIZE: $\frac{3}{4}$ " BSP(M) inlets.
SCOPE: Manufacturer recommended maximum working pressure: DHW - 9.5 bar, Heating - 2 bar & maximum operating temperature: DHW - 60°C, Heating - 85°C. Hygienic Purposes: Non-metallic materials suitable for continuous use up to 60°C.
MARKING Danfoss, PN, WRAS on unit case.
MATERIALS Non-metallic materials assessed (BS6920) to point of discharge.
BACKFLOW PROTECTION NOTES No supply pipe or secondary circuit shall be permanently connected to a closed circuit for filling a heating system unless it incorporates an appropriate backflow prevention device.
ADDITIONAL NOTES All water contact & exposed components satisfy opacity requirements. Sealed primary circuits and /or secondary hot water systems shall incorporate a means for accommodating the thermal expansion of water to prevent any discharge from the circuit and/or system except in an emergency situation.

Extra Notes

13 BIBLIOGRAPHY

- [1] *BESA (Building Engineering Services Association) UK HIU (Heat Interface Unit) Test regime Technical Specification, V3-Rev002: March 2026*
- [2] *Technical Standard for UK HIU Test Regime - Space Heating, Low Temperature, Indirect HEATING MODULE 2-DH55 Indirect, V1-Rev002: March 2026*
- [3] *Technical Standard for UK HIU Test Regime - Domestic Hot Water, Low Temperature, Keep Warm HOT WATER MODULE 8-DH55-KWarm, V1-Rev001: March 2026*

Report Issue No	Reason for Report Update
1	Original issue
2	Information changes and updates
3	Post DHW draw off changed from m ³ to L
4	Technical Information Changes of Standard names
5	Figure 1 updated, test 11b information adjusted. 12b, 12d graphs adjusted alongside values in table 12, 15 and 20

THIS PAGE IS INTENTIONALLY LEFT BLANK

THIS PAGE IS INTENTIONALLY LEFT BLANK



1 Malmo Road
Sutton Fields
Kingston upon Hull, HU7 0YF

+44 (0) 1482 877500
enertekinternational.com
Registered in England No. 2262638

