

# BESA HIU Test Report

vTherm°e HI / HWI / 004 / S  
Modules Tested: 1, 2, 7 & 8

**Client: Vital Energi**

Project Number: E5201 Report Issue: 4

02 June 2026

Prepared By: 

Jack Scargill – Project Engineer

Approved By: 

Simon Broxham – Operations Manager



THIS PAGE IS INTENTIONALLY LEFT BLANK

## DISCLAIMER

This report is confidential to the client named on the front cover.

This report may be stored, transmitted, or reproduced in full by the named client, however if the report is to be placed in the public domain or used for publicity / promotional purposes please inform a director of Enertek International Ltd.

The report must not be reproduced in part, edited, abridged or any extracts used for any purpose whatsoever without written permission from a director of Enertek International Ltd.

The client remains responsible for any data supplied by the client for use in this report. If this data could affect the test results this will be noted in the report.

Any test results contained in this report apply only to the specific sample(s) tested as described in the report.

This report does not imply or indicate any element of commercial approval, recommendation, or promotion by Enertek International Ltd.

Enertek' s default decision rule is in accordance with ILAC-G8:09/2019 simple acceptance.

## CONTENTS

<b>1</b>	<b>EXECUTIVE SUMMARY .....</b>	<b>8</b>
<b>2</b>	<b>BRIEF.....</b>	<b>9</b>
<b>3</b>	<b>DEFINITIONS.....</b>	<b>10</b>
<b>4</b>	<b>INTRODUCTION .....</b>	<b>13</b>
	4.1 Installation of Appliance .....	13
	4.2 Appliance Details .....	13
	4.3 Appliance Design Pressures and Temperatures .....	13
<b>5</b>	<b>TEST METHOD .....</b>	<b>14</b>
	5.1 Test Regime.....	14
<b>6</b>	<b>TEST MODULE 1 – SPACE HEATING, HIGH TEMPERATURE, DH70 INDIRECT .....</b>	<b>16</b>
	6.1 Test Module 1 Information.....	16
	6.2 Test Module 1 Results.....	16
<b>7</b>	<b>TEST MODULE 2 – SPACE HEATING, LOW TEMPERATURE, DH55 INDIRECT .....</b>	<b>21</b>
	7.1 Test Module 2 Information.....	21
	7.2 Test Module 2 Results.....	21
<b>8</b>	<b>TEST MODULE 7 – DHW, HIGH TEMPERATURE, DH70-KWARM .....</b>	<b>26</b>
	8.1 Test Module 7 Information.....	26
	8.2 Test 11a Information .....	26
	8.3 Test 11a Results .....	27
	8.4 Test 12a / 12c Information .....	29
	8.5 Test 12a / 12c Results .....	29
	8.6 Test 13a Information .....	33
	8.7 Test 13a Results .....	33
	8.8 Test 21a Information .....	36
	8.9 Test 21a Results .....	36
	8.10 Test 22a Information .....	39
	8.11 Test 22a Results.....	39
<b>9</b>	<b>TEST MODULE 8 – DHW, LOW TEMPERATURE, DH55-KWARM.....</b>	<b>41</b>
	9.1 Test Module 8 Information.....	41
	9.2 Test 11b Information .....	41
	9.3 Test 11b Results.....	42
	9.4 Test 12b / 12d Information.....	44
	9.5 Test 12b / 12d Results.....	44
	9.6 Test 13b Information .....	48
	9.7 Test 13b Results.....	48
	9.8 Test 21b Information .....	51
	9.9 Test 21b Results.....	51
	9.10 Test 22b Information.....	54
	9.11 Test 22b Results.....	54
<b>10</b>	<b>CONCLUSIONS .....</b>	<b>56</b>
<b>11</b>	<b>EQUIPMENT AND INSTRUMENT LIST .....</b>	<b>57</b>
<b>12</b>	<b>APPENDIX A.....</b>	<b>59</b>
	12.1 VWARD Calculations for Modules 1 & 7 .....	59
	12.2 VWARD Calculations for Modules 2 & 8 .....	60

<b>13</b>	<b>APPENDIX B.....</b>	<b>61</b>
	13.1 Appliance Documentation.....	61
	13.2 Appliance Photographs .....	63
<b>14</b>	<b>APPENDIX C.....</b>	<b>66</b>
	14.1 UK Declaration of Conformity .....	66
	14.3 Water Regulation 4 Certificate.....	67
<b>15</b>	<b>BIBLIOGRAPHY .....</b>	<b>68</b>

## List of Figures

Figure 1 - EIL's HIU Test Rig Schematic which is taken from Appendix B, Figure 4, of Technical Standard for UK HIU Test Regime V3-Rev002.....	15
Figure 2 - Test 01a Key Metrics.....	18
Figure 3 - Test 01b Key Metrics.....	19
Figure 4 - Test 01c Key Metrics.....	20
Figure 5 - Test 01d Key Metrics.....	23
Figure 6 - Test 01e Key Metrics.....	24
Figure 7 - Test 01f Key Metrics.....	25
Figure 8 - Test 11a Key Metrics.....	28
Figure 9 - Test 12a Key Metrics.....	31
Figure 10 - Test 12c Key Metrics.....	32
Figure 11 - Test 13a Key Metrics.....	35
Figure 12 - Test 21a Key Metrics.....	38
Figure 13 - Test 22a Key Metrics.....	40
Figure 14 - Test 11b Key Metrics.....	43
Figure 15 - Test 12b Key Metrics.....	46
Figure 16 - Test 12d Key Metrics.....	47
Figure 17 - Test 13b Key Metrics.....	50
Figure 18 - Test 21b Key Metrics.....	53
Figure 19 - Test 22b Key Metrics.....	55
Figure 20 - HIU with Outer Case Fitted.....	63
Figure 21 - HIU with Outer Case Removed.....	64
Figure 22 - Nameplate with Model Details and Serial Number.....	65
Figure 23 - UK Declaration of Conformity.....	66
Figure 24 - Water Reg 4 Certification.....	67

## List of Tables

Table 1 - Appliance Details and Modules Tested.....	8
Table 2 - Modules Tested Pass or Fail Summary.....	8
Table 3 - Modules 1 & 7 VWART Information.....	8
Table 4 - Modules 2 & 8 VWART Information.....	8
Table 5 - Definitions and Abbreviations.....	10
Table 6 - Appliance Details.....	13
Table 7 - Appliance Design Pressures and Temperatures.....	13
Table 8 - Module 1 Tests.....	16
Table 9 - Module 1 Performance Criteria .....	16
Table 10 - Module 1 Best Practice .....	17
Table 11 - Module 1 Test Results.....	17
Table 12 - Module 2 Tests.....	21
Table 13 - Module 2 Performance Criteria .....	21
Table 14 – Module 2 Best Practice.....	22
Table 15 - Module 2 Test Results.....	22
Table 16 - Module 7 Tests.....	26
Table 17 - Module 7 Test 11a Results .....	27
Table 18 - Module 7 Test 11a Performance Criteria.....	27
Table 19 - Module 7 Test 11a Best Practice.....	27
Table 20 - Module 7 Test 12 Results.....	29
Table 21 - Module 7 Test 12 Performance Criteria.....	29
Table 22 - Module 7 Test 12 Best Practice.....	30
Table 23 - Module 7 Test 13a Performance Criteria.....	33
Table 24 - Module 7 Test 13a Results .....	34
Table 25 - Module 7 Test 21a Results .....	36
Table 26 - Module 7 Test 21a Performance Criteria.....	36
Table 27 - Module 7 Test 21a Best Practice.....	37
Table 28 - Module 7 Test 22a Results .....	39
Table 29 - Module 7 Test 22a Performance Criteria.....	39
Table 30 - Module 7 Test 22a Best Practice.....	39
Table 31 - Module 8 Tests.....	41
Table 32 - Module 8 Test 11b Results.....	42
Table 33 - Module 8 Test 11b Performance Criteria.....	42
Table 34 - Module 8 Test 11b Best Practice.....	42
Table 35 - Module 8 Test 12 Results .....	44
Table 36 - Module 8 Test 12 Performance Criteria.....	44
Table 37 - Module 8 Test 12 Best Practice.....	45
Table 38 - Module 8 Test 13b Performance Criteria.....	48
Table 39 - Module 8 Test 13b Results.....	49
Table 40 - Module 8 Test 21b Results.....	51
Table 41 - Module 8 Test 21b Performance Criteria.....	51
Table 42 - Module 8 Test 21b Best Practice.....	52
Table 43 - Module 8 Test 22b Results.....	54
Table 44 - Module 8 Test 22b Performance Criteria.....	54
Table 45 - Module 8 Test 22b Best Practice.....	54
Table 46 - Appliance Documentation .....	61

# 1 EXECUTIVE SUMMARY

1.1.1 The Vital Energi vTherm°e HI / HWI / 004 / S HIU underwent testing to the BESA Technical Standard for UK HIU Test Regime, V3-Rev002: March 2026. Modules 1, 2, 7 & 8 were tested. Summary tables can be seen below, with further technical data shown in each respective test module chapter of this report. VWART calculations can be found within APPENDIX A.

1.1.2 It should be noted that all VWART figures are to within  $\pm 2^{\circ}\text{C}$  tolerance.

Table 1 - Appliance Details and Modules Tested

<b>Manufacturer:</b>	Vital Energi
<b>Model:</b>	vTherm°e HI / HWI / 004 / S
<b>Modules:</b>	1, 2, 7 & 8

Table 2 - Modules Tested Pass or Fail Summary

<b>Module 1:</b>	Pass
<b>Module 2:</b>	Pass
<b>Module 7:</b>	Pass
<b>Module 8:</b>	Pass

Table 3 - Modules 1 & 7 VWART Information

	<b>VWART (°C)</b>	<b>Volume (m<sup>3</sup>)</b>
<b>DHW</b>	13	24.9
<b>Standby</b>	36	13.8
<b>Space Heating</b>	35	33.7

	<b>VWART (°C)</b>
<b>Summer</b>	21
<b>Winter</b>	28
<b>Overall</b>	24

Table 4 - Modules 2 & 8 VWART Information

	<b>VWART (°C)</b>	<b>Volume (m<sup>3</sup>)</b>
<b>DHW</b>	17	38.0
<b>Standby</b>	40	35.7
<b>Space Heating</b>	35	62.0

	<b>VWART (°C)</b>
<b>Summer</b>	28
<b>Winter</b>	32
<b>Overall</b>	30

## 2 BRIEF

- 2.1.1 EnerTek International Limited (EIL), were contracted to receive, install and commission a production sample of the Vital Energi vTherm°e HI / HWI / 004 / S HIU.
- 2.1.2 To perform the tasks required for assessing the efficiency of Domestic Hot Water (DHW) and Space Heating (SH) as per the BESA Technical Standard for UK HIU Test Regime, V3-Rev002: March 2026, a publicly available online test regime. This is here-on referred to as the Test Regime throughout this document.
- 2.1.3 To provide a report detailing the tests carried out and generated results in accordance with the Test Regime criteria, including calculations for Volume Weighted Average Return Temperatures (VWART).

### 3 DEFINITIONS

3.1.1 The following definitions and abbreviations which have been used within this report can be found in Table 5 below.

Table 5 - Definitions and Abbreviations

<b>Symbol</b>	<b>Description</b>
$t_{10}$	Temperature, primary source
$t_{11}$	Temperature, primary side flow connection
$t_{12}$	Temperature, primary side return connection
$t_{21}$	Temperature, space heating system return connection
$t_{22}$	Temperature, space heating system flow connection
$t_{31}$	Temperature, cold water supply
$t_{32}$	Temperature, domestic hot water flow from HIU
$t_{b1}$	Temperature, primary side bypass flow (for non-keep warm configuration)
$t_{b2}$	Temperature, primary side bypass return (for non-keep warm configuration)
$q_1$	Volume flow, primary side
$q_2$	Volume flow, space heating system
$q_3$	Volume flow, domestic hot water
$P_{11}$	Static pressure, primary side flow connection
$P_{12}$	Static pressure, primary side return connection
$P_{21}$	Static pressure, space heating system return connection
$P_{22}$	Static pressure, space heating system flow connection
$P_{31}$	Static pressure, cold water supply
$P_{32}$	Static pressure, domestic hot water flow from HIU
$dP_1$	Differential pressure, primary system across HIU
$dP_2$	Differential pressure, space heating system across HIU
$dP_3$	Differential pressure, domestic hot water across HIU
$Q_{DHW}$	Estimated annual energy demand per year for hot water
$Q_{SH}$	Estimated annual energy demand per year for space heating
$n_{DHW}$	Number of DHW events per year

$H_1$	Arithmetic mean of primary side power recorded during test
$H_2$	Arithmetic mean of space heating power recorded during test
$H_3$	Arithmetic mean of DHW power recorded during test
$h_{DHW}$	Annual hours that HIU is producing DHW
$h_{SH}$	Annual hours that HIU is producing space heating
$h_{KWM}$	Annual hours that HIU is in keep warm mode
$h_{NKWM}$	Annual hours that HIU is in non-keep warm mode
$V_{DHW}$	Volume of primary water recorded during and post-DHW test
$V_{SH}$	Volume of primary water recorded during space heating tests
$V_{KWM}$	Volume of primary water recorded during keep warm test
$V_{NKWM}$	Volume of primary water recorded during non-keep warm test
$Prop_{Summer}$	Proportion of year HIU is operating in “summer” mode
$Prop_{Winter}$	Proportion of year HIU is operating in “winter” mode
$VWART_{DHW}$	DHW Volume Weighted Average Return Temperature
$VWART_{SH}$	Space Heating Volume Weighted Average Return Temperature
$VWART_{KWM}$	Keep Warm Volume Weighted Average Return Temperature
$VWART_{NKWM}$	Non-Keep Warm Volume Weighted Average Return Temperature
$VWART_{WINTER}$	Annual Volume Weighted Average Return Temperature for Heating Period
$VWART_{SUMMER}$	Annual Volume Weighted Average Return Temperature for Non-Heating Period
$VWART_{HIU}$	Total Annual Volume Weighted Average Return Temperature
$W_{thermal}$	Thermal energy use
$W_{electrical}$	Electrical energy use
$SH_{PROP}$	Annual heating period
$NSH_{PROP}$	Annual non-space heating period
TMV	Thermostatic mixing valve
TRV	Temperature regulating valve
UFH	Underfloor heating
DHW	Domestic hot water
HIU	Heat interface unit

DPCV	Differential pressure control valve
DRV	Double regulating valve
SH	Space heating
UKAS	United Kingdom Accreditation Service
EIL	Enertek International Limited
PHE	Plate Heat Exchanger

## 4 INTRODUCTION

### 4.1 Installation of Appliance

4.1.1 The appliance was installed and commissioned (as received) and as defined in the product literature provided. Testing was carried out without further adjustment other than disabling the internal space heating pump and adjusting the setting of the SH and DHW set points through the user interface on the HIU controller to suit the conditions of the HIU test rig.

4.1.2 The HIU rig schematic is shown within Figure 1.

The HIU was commissioned in accordance with the technical manual / installation guide provided by Vital Energi. The location of which can be found within the references section of this report.

### 4.2 Appliance Details

4.2.1 Details of the Vital Energi vTherm°e HI / HWI / 004 / S HIU appliance are given in Table 6. Photographs of the installed appliance are given in Figure 20, Figure 21 and Figure 22.

4.2.2 The UK declaration of conformity (CE or UKCA or equivalent) and water regulation 4 certificate can be found within APPENDIX C.

Table 6 - Appliance Details

Item	Description
Manufacturer	Vital Energi
Model	vTherm°e HI / HWI / 004 / S
Serial Number	102000-000001
Year of Manufacture	2025
DHW Priority	Yes
EUT Number	0925
Date Test Item Received	17/11/2025

### 4.3 Appliance Design Pressures and Temperatures

4.3.1 The maximum design pressures and temperatures of the Vital Energi vTherm°e HI / HWI / 004 / S appliance for the primary side and the secondary side for both space heating and DHW are given in Table 7.

Table 7 - Appliance Design Pressures and Temperatures

Item	Pressure (bar)	Temperature (°C)	Differential Pressure (bar)
Primary Side	16	90	6
Secondary Side Space Heating	2.5	80	N/A
Secondary Side DHW	10	60	N/A

## 5 TEST METHOD

### 5.1 Test Regime

5.1.1 The testing described in this report was carried out in accordance with the test regime. The test regime outlines a series of static and dynamic tests to determine the performance of a HIU's DHW and SH functions. The test regime outlines the test method including the reporting of the results, the performance requirements and the VWART calculations.

5.1.2 Testing was carried out in accordance with Test Module 1.

5.1.3 Testing was carried out in accordance with Test Module 2.

5.1.4 Testing was carried out in accordance with Test Module 7.

5.1.5 Testing was carried out in accordance with Test Module 8.

### 5.2 Measurement & Uncertainties

5.2.1 All measurements and uncertainties adhere to the requirements stipulated in the BESA Test Regime. All measurements were sampled at a rate of 1 Hz for all tests.

5.2.2 The BESA uncertainties of measurement requirements are as follows:

- Differential Pressure,  $\pm 1.0$  kPa
- Temperature,  $\pm 0.1$  °C
- Volume Flow ( $\geq 0.06$  l/s)  $\pm 1.5$  %
- Volume Flow ( $< 0.06$  l/s),  $\pm 3.0$  %

Note: the time constant for the temperature sensors is less than 1.5 s. The time constant for the differential pressure sensors is less than 5s.

5.2.3 EIL's reported uncertainty is based on a standard uncertainty by a coverage factor  $K=2$ , providing a level of confidence of approximately 95%. The uncertainty evaluation has been carried out in accordance with UKAS requirements. The EIL equipment list and uncertainties are given in shown within chapter 11.

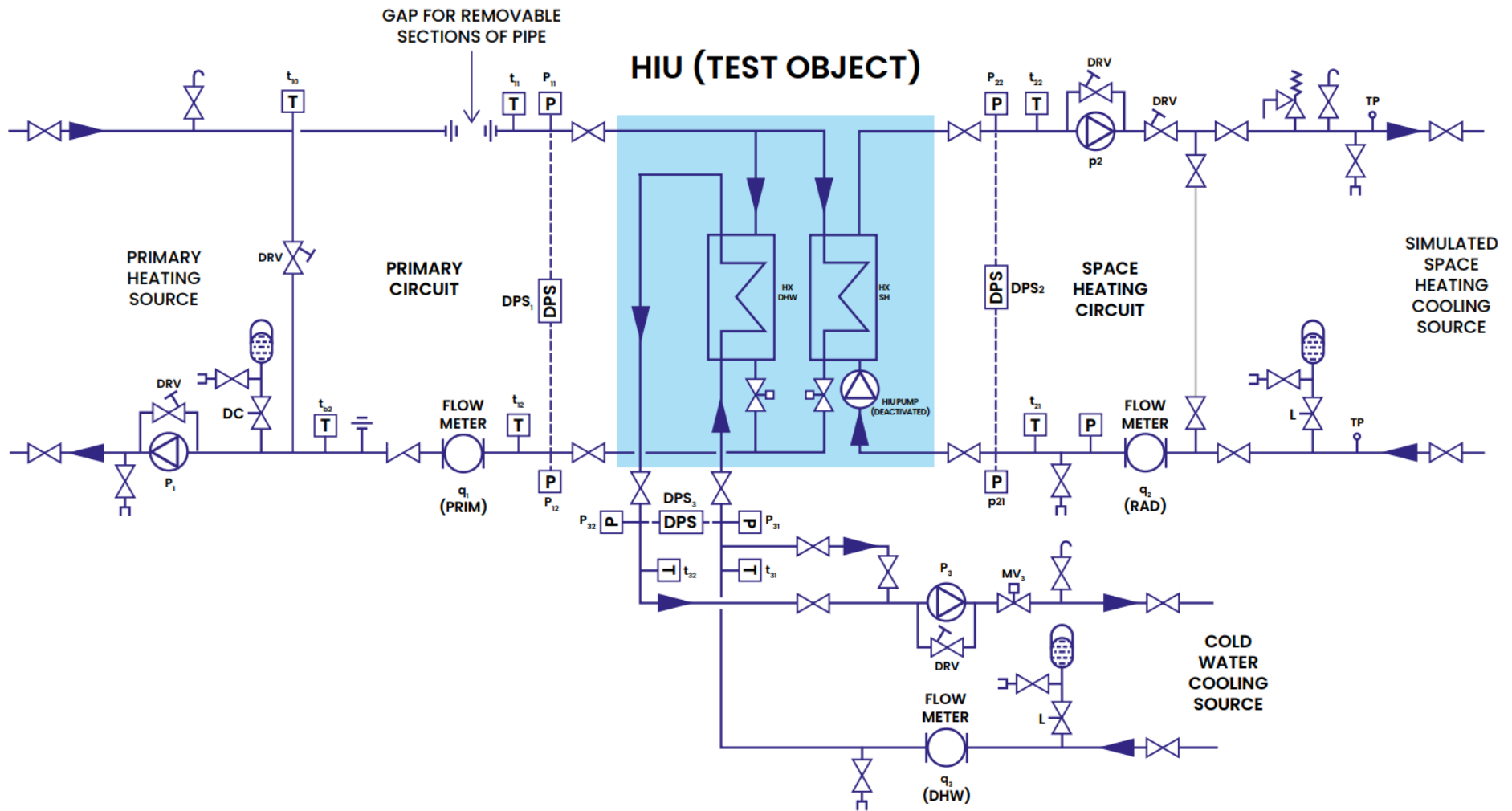

Figure 1 - EIL's HIU Test Rig Schematic which is taken from Appendix B, Figure 4, of Technical Standard for UK HIU Test Regime V3-Rev002

## 6 TEST MODULE 1 – SPACE HEATING, HIGH TEMPERATURE, DH70 INDIRECT

### 6.1 Test Module 1 Information

6.1.1 Objective: Perform static testing to investigate the performance characteristics of the HIU when indirectly meeting a space-heating load given a 55°C/35°C tertiary heating circuit and 70°C primary flow temperature.

6.1.2 The following set of tests are from Test Module 1 – Space Heating, High Temperature, Indirect Heating Module 1 - DH70 Indirect – V1-Rev002: 2026.

Table 8 - Module 1 Tests

Module 1 Tests	
01a	DH/70C, Space Heating Indirect 0.5 kW, 55/35°C tertiary, 50 kPa
01b	DH/70C, Space Heating Indirect 1 kW, 55/35°C tertiary, 200 kPa
01c	DH/70C, Space Heating Indirect 4 kW, 55/35°C tertiary, 50 kPa

### 6.2 Test Module 1 Results

6.2.1 Performance criteria results can be seen in Table 9, test result data can be seen in Table 11 and key metrics can be found in Figure 2, Figure 3 and Figure 4. Best practice criteria can be found in Table 10.

Table 9 - Module 1 Performance Criteria

Module 1 Tests Performance Criteria	
Performance Criteria, Fail if:	PASS/FAIL
VWART is above 37°C (to one decimal point)	PASS
Space heating flow temperature, t22, is not maintained at 55°C ± 5.0°C (to one decimal place) for more than one second	PASS
Average space heating flow temperature, t22, across the test is not 55°C ±0.5°C (to one decimal place) (01c only)	PASS
Average space heating flow temperature, t22, across the test is not 55°C -0.5°C / +2.0°C (to one decimal place) (01a and 01b)	PASS

Table 10 - Module 1 Best Practice

<b>Module 1 – Best Practice Criteria</b>	
<b>Best Practice Criteria if:</b>	<b>Best Practice</b>
VWART is less than or equal to 36°C (to one decimal point)	Achieved
Average space heating flow temperature, t <sub>22</sub> , across all three tests is within 55°C ±0.5°C	Achieved

Table 11 - Module 1 Test Results

<b>Module 1 Test Results</b>				
<b>Parameter</b>	<b>Symbol</b>	<b>01a (0.5kW)</b>	<b>01b (1kW)</b>	<b>01c (4kW)</b>
Temperature, primary side flow connection	t <sub>11</sub> (°C)	69.8	70.2	70.2
Temperature, primary side return connection	t <sub>12</sub> (°C)	34.3	34.8	36.2
Volume flow, primary side	q <sub>1</sub> (l/s)	0.002	0.007	0.026
Differential pressure, primary system across HIU	dP <sub>1</sub> (kPa)	53	199	52
Arithmetic mean of primary side power recorded during test	H <sub>1</sub> (W)	344.1	1036.2	3739.7
Temperature, space heating system return connection	t <sub>21</sub> (°C)	34.9	34.8	35.0
Temperature, space heating system flow connection	t <sub>22</sub> (°C)	54.9	55.5	55.0
Volume flow, space heating system	q <sub>2</sub> (l/s)	0.0063	0.012	0.047
Differential pressure, space heating system across HIU	dP <sub>2</sub> (kPa)	13	12	11
Arithmetic mean of space heating power during test	H <sub>2</sub> (W)	525.8	1068.7	3932.0
Volume Weighted Avg. Return Temp	VWART (°C)	34	35	36
<b>Overall VWART (°C)</b>		<b>35</b>		

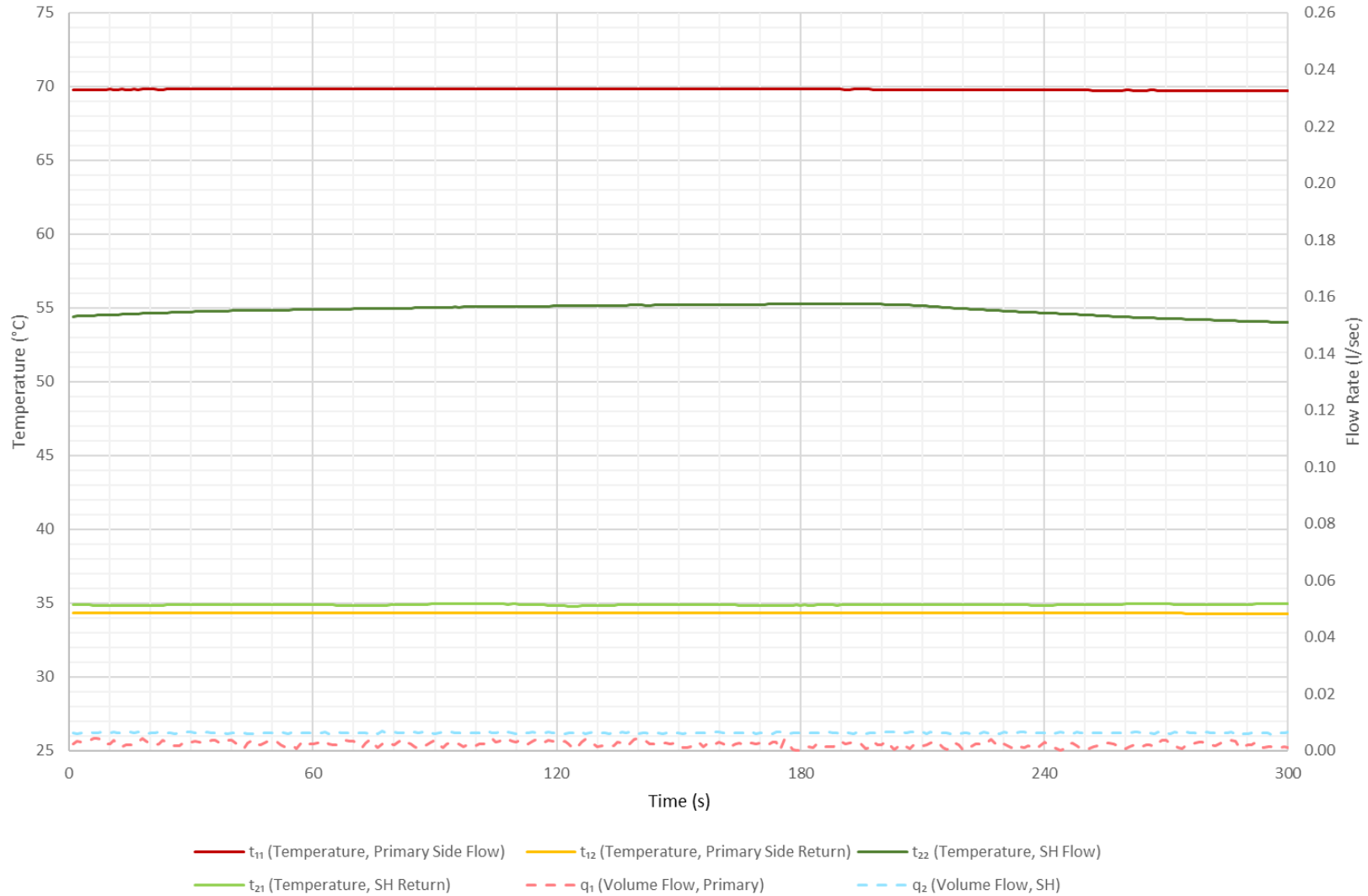

Figure 2 - Test 01a Key Metrics

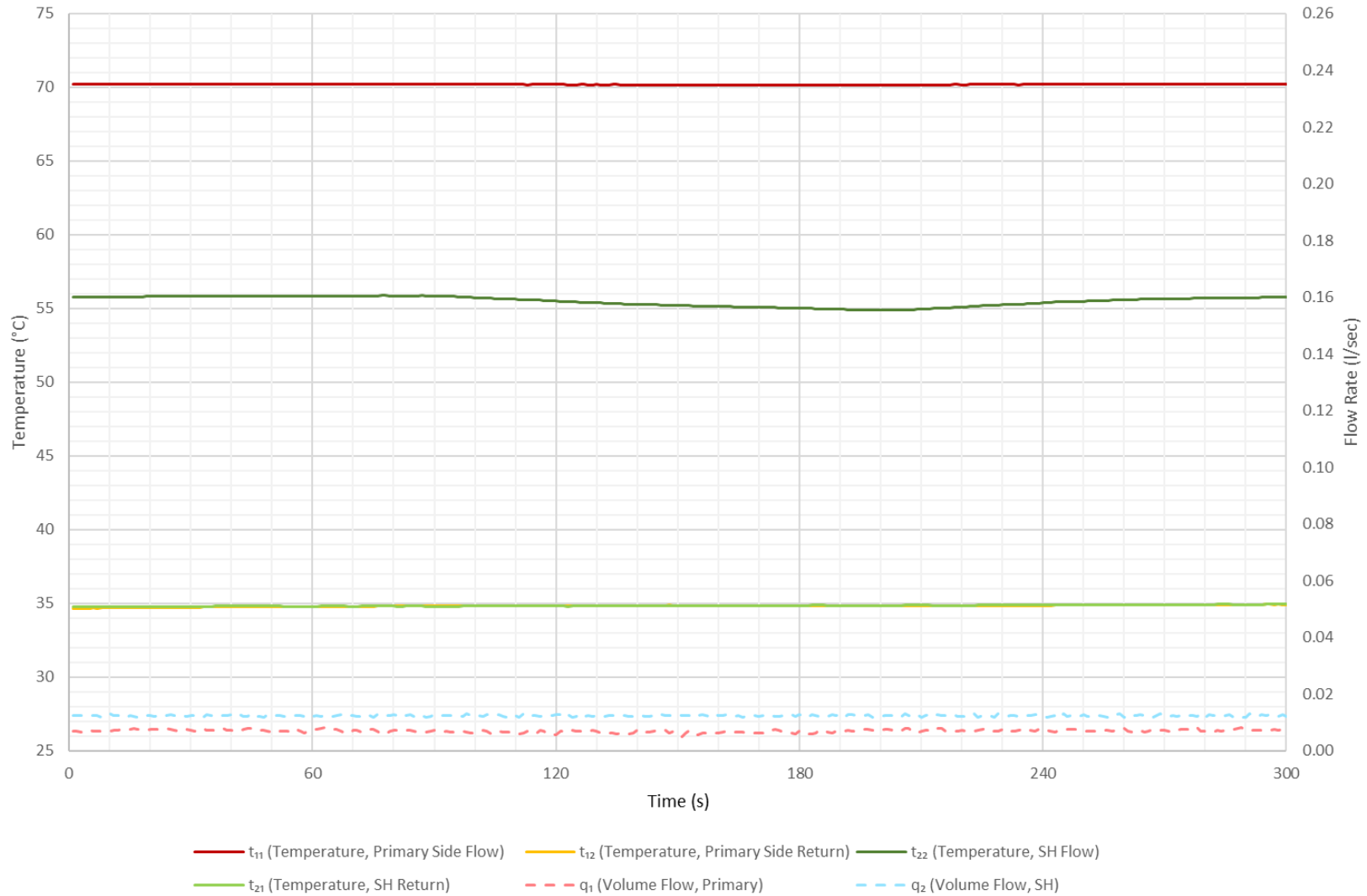

Figure 3 - Test 01b Key Metrics

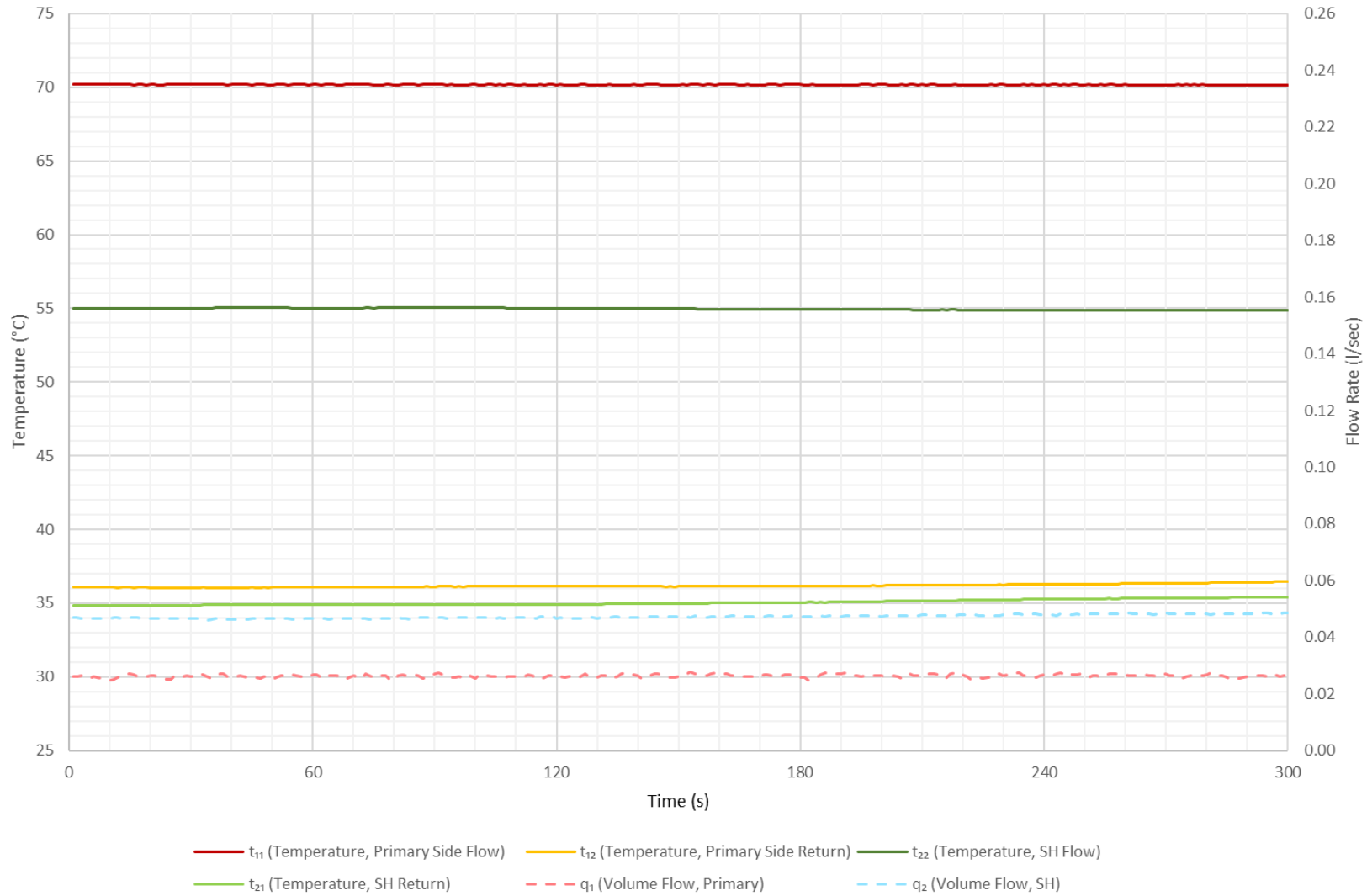

Figure 4 - Test 01c Key Metrics

## 7 TEST MODULE 2 – SPACE HEATING, LOW TEMPERATURE, DH55 INDIRECT

### 7.1 Test Module 2 Information

7.1.1 Objective: Perform static testing to investigate the performance characteristics of the HIU when indirectly meeting a space-heating load given a 45°C/35°C tertiary heating circuit and 55°C primary flow temperature.

7.1.2 The following set of tests are from Test Module 2 - Space Heating, Low Temperature, Indirect Heating Module 2 - DH55 Indirect – V1- Rev002: 2026

Table 12 - Module 2 Tests

Module 2 Tests	
01d	DH/55C, Space Heating Indirect 0.5 kW, 45/35°C tertiary, 50 kPa
01e	DH/55C, Space Heating Indirect 1 kW, 45/35°C tertiary, 200 kPa
01f	DH/55C, Space Heating Indirect 4 kW, 45/35°C tertiary, 50 kPa

### 7.2 Test Module 2 Results

7.2.1 Performance criteria results can be seen in Table 13, test result data can be seen in Table 15 and key metrics can be found in Figure 5, Figure 6 and Figure 7. Best practice criteria can be found in Table 14.

Table 13 - Module 2 Performance Criteria

Module 2 Tests Performance Criteria	
Performance Criteria, Fail if:	PASS/FAIL
VWART is above 37°C (to one decimal point)	PASS
Space heating flow temperature, t22, is not maintained at 45°C ± 5.0°C (to one decimal place) for more than one second	PASS
Average space heating flow temperature, t22, across the test is not 45°C ±0.5°C (to one decimal place) (01f only)	PASS
Average space heating flow temperature, t22, across the test is not 45°C -0.5°C / +2.0°C (to one decimal place) (01d and 01e)	PASS

Table 14 – Module 2 Best Practice

<b>Module 2 – Best Practice Criteria</b>	
<b>Best Practice Criteria if:</b>	<b>Best Practice</b>
VWART is less than or equal to 36°C (to one decimal point)	Achieved
Average space heating flow temperature, t <sub>22</sub> , across all three tests is within 45°C ±0.5°C	Achieved

Table 15 - Module 2 Test Results

<b>Module 2 Test Results</b>				
<b>Parameter</b>	<b>Symbol</b>	<b>01d (0.5kW)</b>	<b>01e (1kW)</b>	<b>01f (4kW)</b>
Temperature, primary side flow connection	t <sub>11</sub> (°C)	55.0	55.3	55.0
Temperature, primary side return connection	t <sub>12</sub> (°C)	34.5	35.3	35.5
Volume flow, primary side	q <sub>1</sub> (l/s)	0.006	0.011	0.051
Differential pressure, primary system across HIU	dP <sub>1</sub> (kPa)	54	202	55
Arithmetic mean of primary side power recorded during test	H <sub>1</sub> (W)	519.1	942.4	4161.1
Temperature, space heating system return connection	t <sub>21</sub> (°C)	34.8	35.4	34.6
Temperature, space heating system flow connection	t <sub>22</sub> (°C)	45.4	44.8	45.1
Volume flow, space heating system	q <sub>2</sub> (l/s)	0.012	0.025	0.095
Differential pressure, space heating system across HIU	dP <sub>2</sub> (kPa)	12	13	7
Arithmetic mean of Space heating power during test	H <sub>2</sub> (W)	528.8	975.2	4133.1
Volume Weighted Avg. Return Temp	VWART (°C)	34	35	36
Overall VWART (°C)		35		

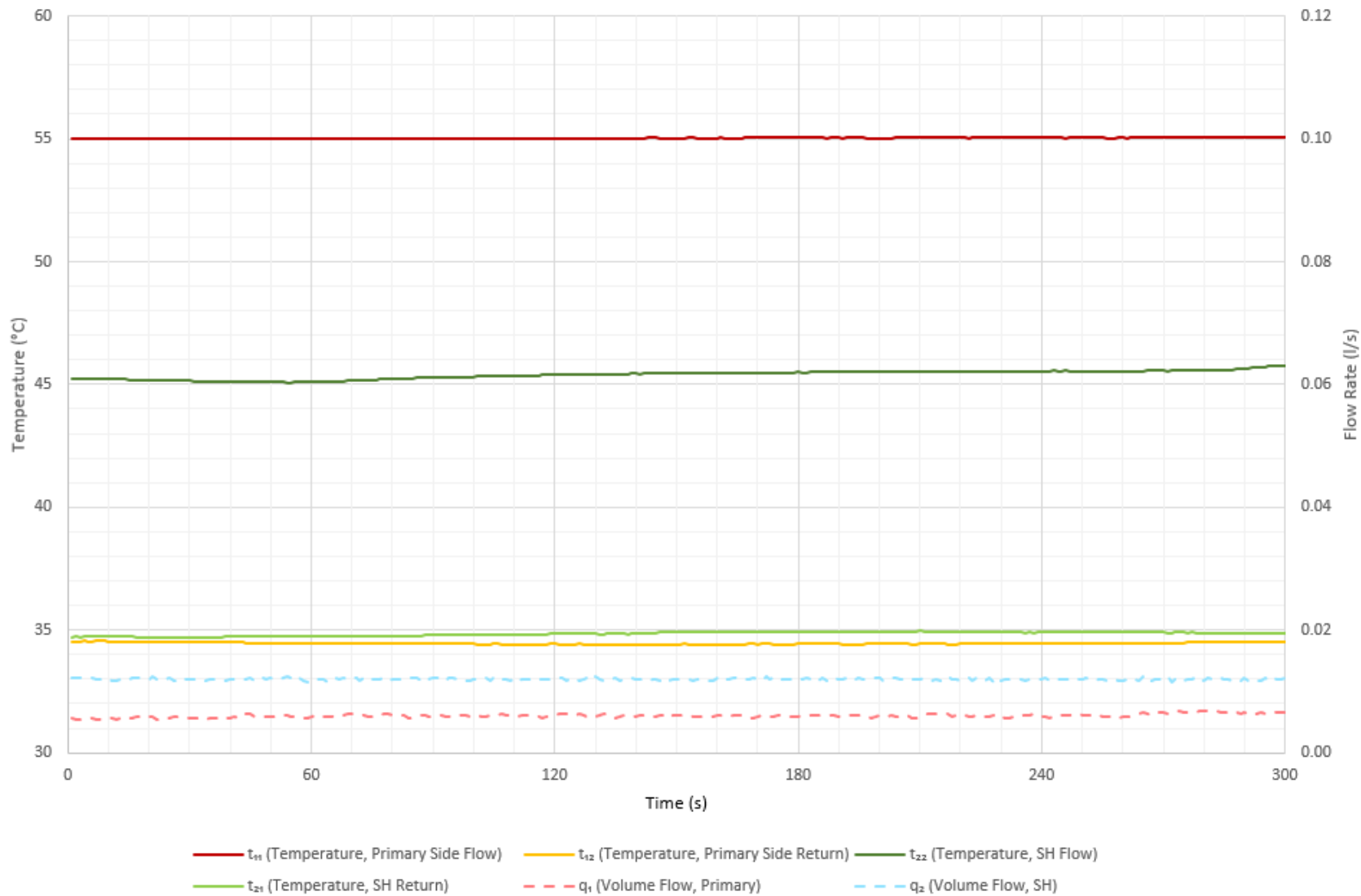

Figure 5 - Test 01d Key Metrics

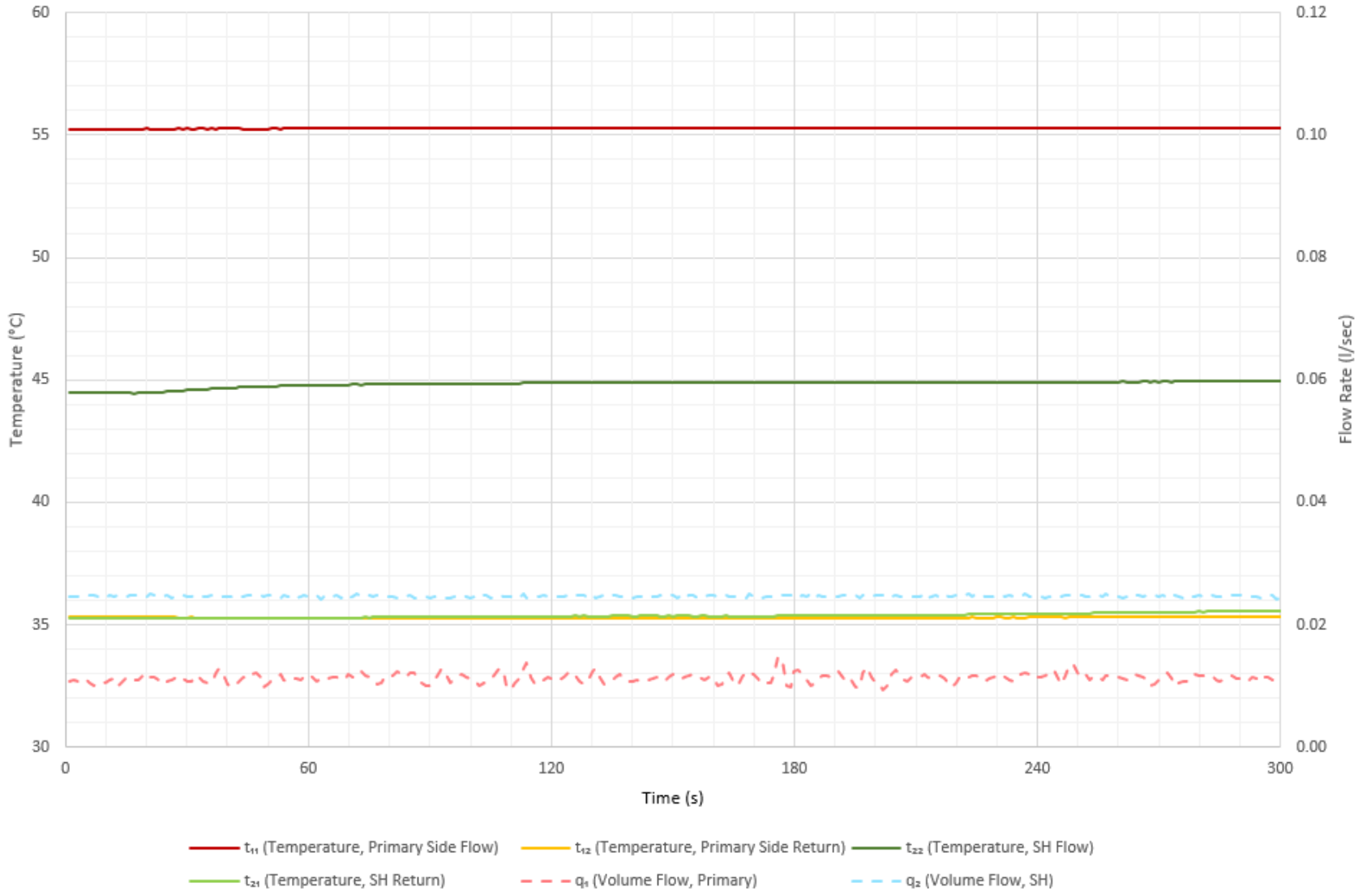

Figure 6 - Test 01e Key Metrics

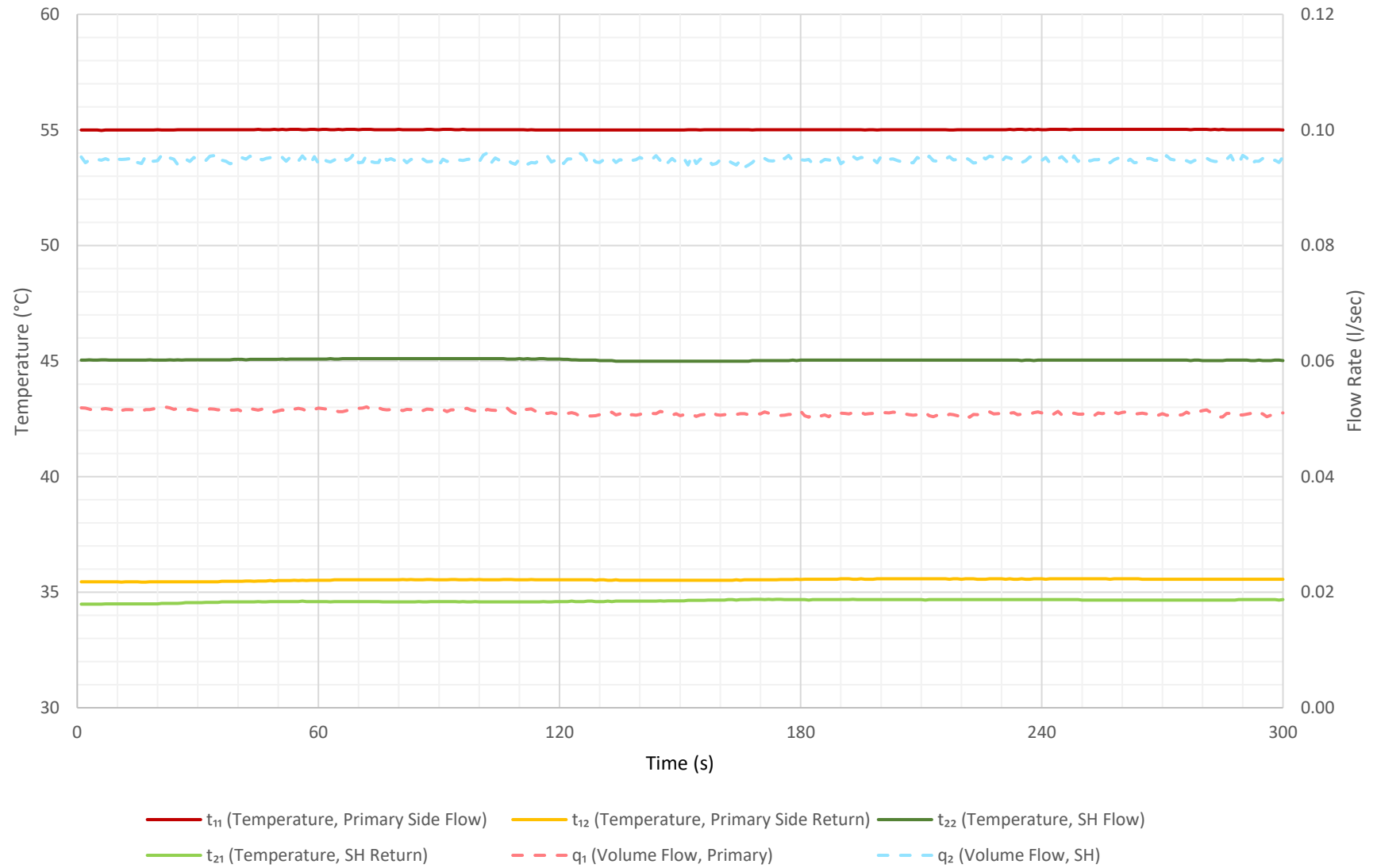

Figure 7 - Test 01f Key Metrics

## 8 TEST MODULE 7 – DHW, HIGH TEMPERATURE, DH70-KWARM

### 8.1 Test Module 7 Information

8.1.1 Objective: To explore the performance of the HIU under changing loads, as would be the case in practical operation. Key performance criteria are speed and consistency of DHW delivery to the customer; DHW remaining at a safe temperature at all times and the volume weighted average return temperature when supplying space heating or DHW.

8.1.2 The following set of tests are from Test Module 7 – Domestic Hot Water, High Temperature, Keep Warm Hot Water Module 7 - DH70 - KWarm – V1-Rev002: 2026.

Table 16 - Module 7 Tests

Module 7 Tests	
11a	DH/70C, DHW only, 50°C DHW, Variable dP
12a	DH/70C, DHW Low Flow, 50°C DHW, 50kPa
12c	DH/70C, DHW Low Flow, 50°C DHW, 200kPa
13a	DH/70C, DHW Load Test, 50°C DHW
21a	DH/70C, DHW Keep Warm, 50°C DHW
22a	DH/70C, DHW Keep Warm Response Time, 50°C DHW

### 8.2 Test 11a Information

8.2.1 Objective: To investigate the performance of the HIU when delivering DHW, at a range of flow rates and differential pressures, given a 70°C primary flow temperature. The test investigates HIU operation in terms of DHW delivery and impacts on primary heat network return temperatures.

### 8.3 Test 11a Results

8.3.1 Performance criteria results can be seen in Table 18, test result data can be seen in Table 17 and key metrics can be found in Figure 8. Best practice criteria can be found in Table 19.

Table 17 - Module 7 Test 11a Results

Module 7 - Test 11a Results			
Parameter	Symbol	Result	
Maximum and minimum values of $t_{32}$ when there is DHW flow	$t_{32}$ (°C)	56.3	45.5
Number of consecutive seconds where $t_{32} > 55^{\circ}\text{C}$	(s)	40	
Volume Weighted Avg. Return Temp	VWART (°C)	13	

Table 18 - Module 7 Test 11a Performance Criteria

Module 7 - Test 11a Performance Criteria	
Performance Criteria, Fail if:	PASS/FAIL
DHW temperature ( $t_{32}$ ) exceeds $60.0^{\circ}\text{C}$ (to one decimal place) for more than 1 second, as this poses a scalding risk	Pass
Primary return temperature ( $t_{12}$ ) exceeds $55.0^{\circ}\text{C}$ (to one decimal place) at any point, as this poses a scaling risk	Pass
VWART is above $20^{\circ}\text{C}$ (to one decimal place)	Pass
DHW temperature ( $t_{32}$ ) is not $50.0^{\circ}\text{C} \pm 1^{\circ}\text{C}$ (to one decimal place) for the final 150 seconds of each of the 180 second DHW flow periods	Pass
DHW temperature ( $t_{32}$ ) is not being maintained at $50.0^{\circ}\text{C} \pm 3^{\circ}\text{C}$ (to one decimal place) for $>150$ seconds of each of the DHW flow periods	Pass
DHW temperature ( $t_{32}$ ) drops below $45.0^{\circ}\text{C}$ (to one decimal place) for more than 5 consecutive seconds, as this would impact resident comfort	Pass

Table 19 - Module 7 Test 11a Best Practice

Module 7 – Test 11a – Best Practice Criteria	
Best Practice Criteria if:	Best Practice
VWART is less than or equal to $15^{\circ}\text{C}$ (to one decimal place)	Achieved
DHW temperature ( $t_{32}$ ) is being maintained at $50.0^{\circ}\text{C} \pm 2^{\circ}\text{C}$ throughout periods of DHW flow	Not achieved
DHW temperature ( $t_{32}$ ) doesn't drop below $45.0^{\circ}\text{C}$ (to one decimal place) for more than 2 consecutive seconds	Achieved



Figure 8 - Test 11a Key Metrics

#### 8.4 Test 12a / 12c Information

- 8.4.1 Objective: To investigate the stability of DHW temperature at low flow rates. During operation, domestic hot water is sometimes drawn off at extremely low flow rates. Test 12 investigates the ability of the system to meet this condition by measuring the temperature at test point  $t_{32}$  at a flow rate of 0.02 l/s.
- 8.4.2 Test 12a performs the low flow test at 50kPa differential pressure
- 8.4.3 Test 12c performs the low flow test at 200kPa differential pressure

#### 8.5 Test 12a / 12c Results

- 8.5.1 The HIU was able to deliver DHW at low flow rate above 45.0°C at the end of the 180 second period of low flow DHW.
- 8.5.2 The HIU was able to deliver stable DHW flow temperature (at  $t_{32}$ ), defined as ability to maintain 50.0 ±3.0°C (1 decimal place) during the last 60 seconds of the test.
- 8.5.3 Performance criteria results can be seen in Table 21, test result data can be seen in Table 20 and key metrics can be found in Figure 9 and Figure 10. Best practice criteria can be found in Table 22.

Table 20 - Module 7 Test 12 Results

Module 7 - Test 12 Results					
Parameter	Symbol	12a Result		12c Result	
Maximum and minimum values of $t_{32}$ when there is low DHW flow	$t_{32}$ (°C)	58.3	46.5	58.2	45.5
Number of consecutive seconds where $t_{32} > 55^{\circ}\text{C}$	(s)	13		12	

Table 21 - Module 7 Test 12 Performance Criteria

Module 7 - Test 12 Performance Criteria	
Performance Criteria, Fail if:	PASS/FAIL
DHW temperature ( $t_{32}$ ) exceeds 60.0°C (to one decimal place) for more than 1 second, as this poses a scalding risk	Pass
Primary return temperature ( $t_{12}$ ) exceeds 55.0°C (to one decimal place) at any point, as this poses a scaling risk	Pass
DHW temperature ( $t_{32}$ ) is not maintained at 50°C ±3°C (to one decimal place) for more than 60 seconds	Pass

Table 22 - Module 7 Test 12 Best Practice

<b>Module 7 – Test 12 – Best Practice Criteria</b>	
<b>Best Practice Criteria if:</b>	<b>Best Practice</b>
DHW temperature (t32) is maintained at 50°C ±2°C (to one decimal place) throughout the test for both test 12a and 12c.	Not Achieved

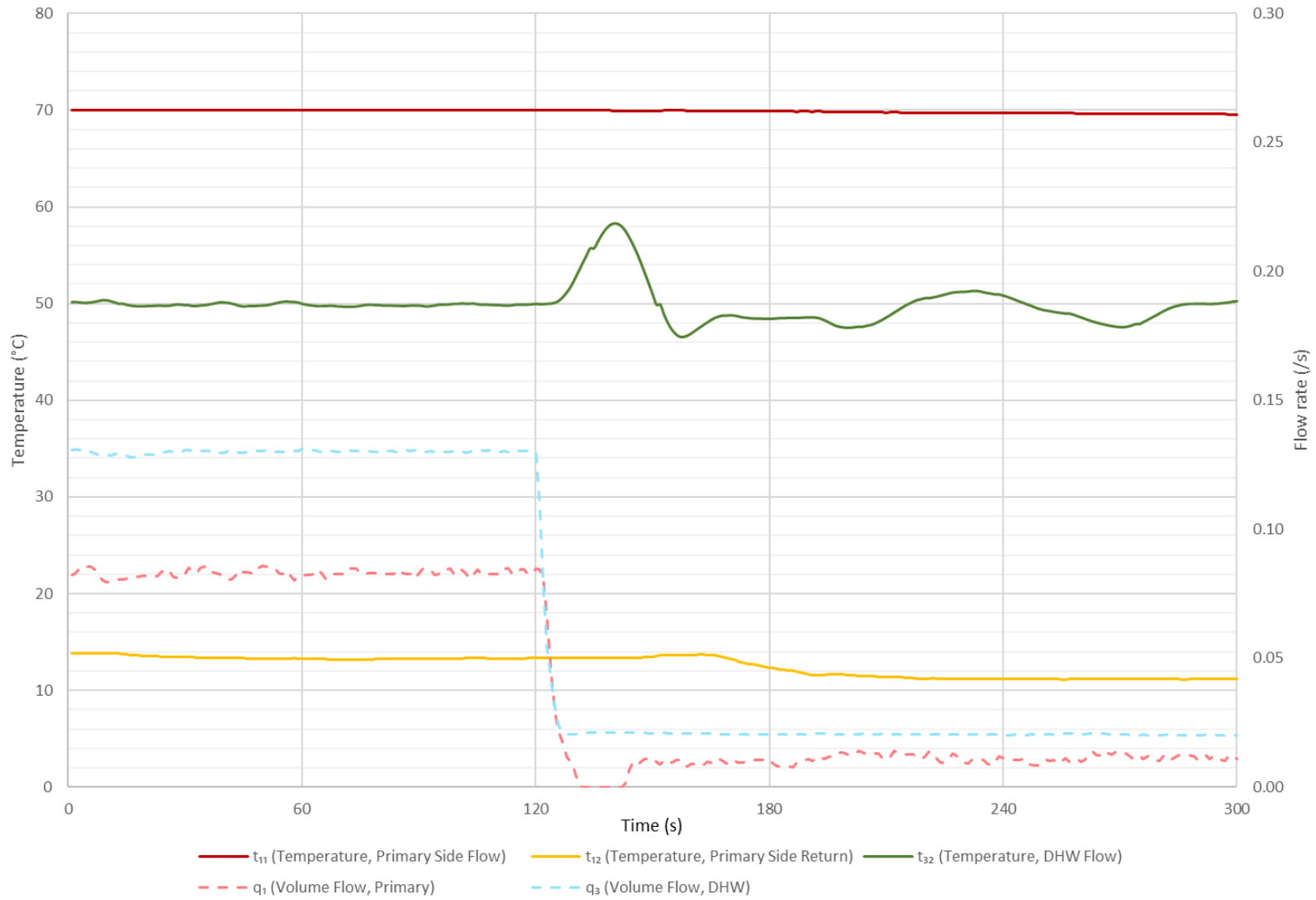

Figure 9 - Test 12a Key Metrics

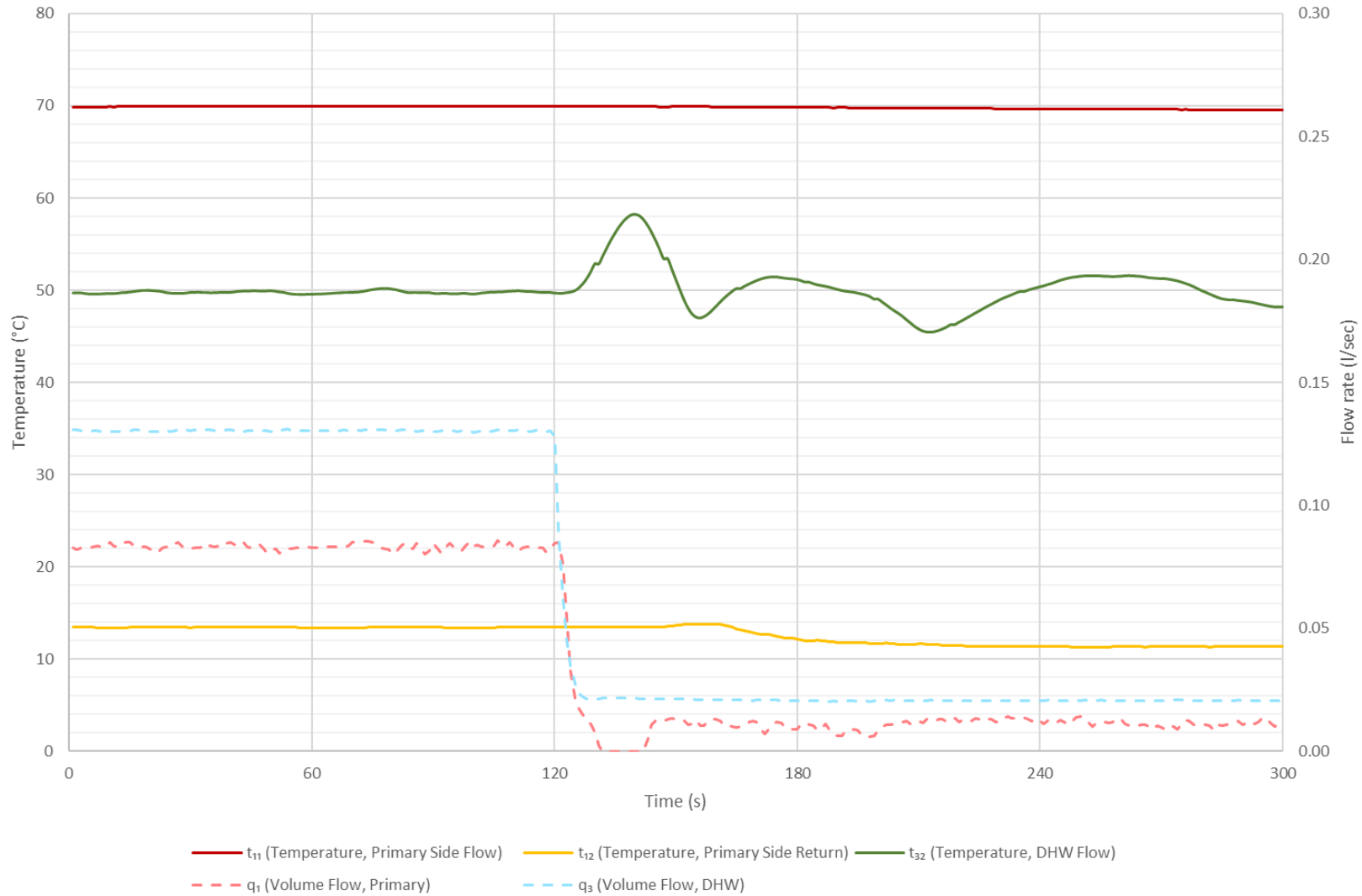

Figure 10 - Test 12c Key Metrics

## 8.6 Test 13a Information

8.6.1 Objective: To measure the maximum heat output (kW) and flow (l/sec) DHW output that can be delivered from the HIU. The HIU shall be set to deliver 50°C and the maximum DHW power output shall be measured with a flow step change and the peak value recorded when the DHW flow temperature is above 45°C.

## 8.7 Test 13a Results

8.7.1 The maximum DHW heat output was recorded as 68.8 kW, with a measured flow rate of 0.416l/s, when producing minimum DHW at 45°C or above (Temperature achieved at final step 49.7°C).

8.7.2 The recorded DHW line pressure drop across the HIU was 69 kPa.

8.7.3 The number of consecutive seconds where  $t_{32} > 55^{\circ}\text{C}$  was 7 seconds.

8.7.4 Performance criteria results can be seen in Table 23, test result data can be seen in Table 24 and key metrics can be found in Figure 11.

8.7.5 The unit has a maximum flowrate of 0.416 L/s  $\pm$  0.017L/s, which is why the test was stopped at the 0.42 L/s step.

Table 23 - Module 7 Test 13a Performance Criteria

<b>Module 7 - Test 13a Performance Criteria</b>	
<b>Performance Criteria, Fail if:</b>	<b>PASS / FAIL</b>
DHW (at $t_{32}$ ) is not maintained at $50^{\circ}\text{C} \pm 1.0^{\circ}\text{C}$ (to one decimal place) at 0.13 l/s flow rate, as the HIU must be able to produce DHW to the target temperature at a moderate load	Pass
DHW temperature ( $t_{32}$ ) exceeds $60.0^{\circ}\text{C}$ (to one decimal place) for more than 1 second, as this poses a scalding risk	Pass
Primary return temperature ( $t_{12}$ ) exceeds $55.0^{\circ}\text{C}$ (to one decimal place) at any point, as this poses a scaling risk	Pass

Table 24 - Module 7 Test 13a Results

Module 7 - Test 13a Results – Mean Average of Last 10 Seconds											
Parameter	Symbol	0.15 l/s (25kW)	0.18 l/s (30kW)	0.21 l/s (35kW)	0.24 l/s (40kW)	0.27 l/s (45kW)	0.30 l/s (50kW)	0.33 l/s (55kW)	0.36 l/s (60kW)	0.39 l/s (65kW)	0.42 l/s (70kW)
Temperature, primary side flow connection	$t_{11}$ (°C)	69.6	69.8	69.9	70.0	70.0	70.0	70.0	70.0	70.0	<b>70.0</b>
Temperature, primary side return connection	$t_{12}$ (°C)	13.9	13.7	13.7	14.0	14.1	14.2	14.2	14.9	14.9	<b>15.1</b>
Volume flow, primary side	$q_1$ (l/s)	0.105	0.128	0.148	0.169	0.191	0.211	0.240	0.264	0.284	<b>0.301</b>
Arithmetic mean of primary side power recorded during test	$H_1$ (kW)	24.4	30.1	34.7	39.7	44.6	49.2	56.0	60.8	65.3	<b>69.1</b>
Temperature, cold water supply	$t_{31}$ (°C)	10.5	10.5	10.5	10.6	10.6	10.1	9.8	10.1	10.0	<b>10.2</b>
Temperature, domestic hot water flow from HIU	$t_{32}$ (°C)	49.9	50.0	50.0	50.0	49.9	49.7	50.2	50.8	50.3	<b>49.7</b>
Volume flow, domestic hot water	$q_3$ (l/s)	0.153	0.183	0.214	0.244	0.273	0.301	0.333	0.361	0.392	<b>0.416</b>
Differential pressure, domestic hot water across HIU	$dP_3$ (kPa)	18	22	26	30	35	40	47	55	62	<b>69</b>
Arithmetic mean of DHW power recorded during test	$H_3$ (kW)	25.2	30.2	35.3	40.2	44.8	49.8	56.3	61.5	65.9	<b>68.8</b>

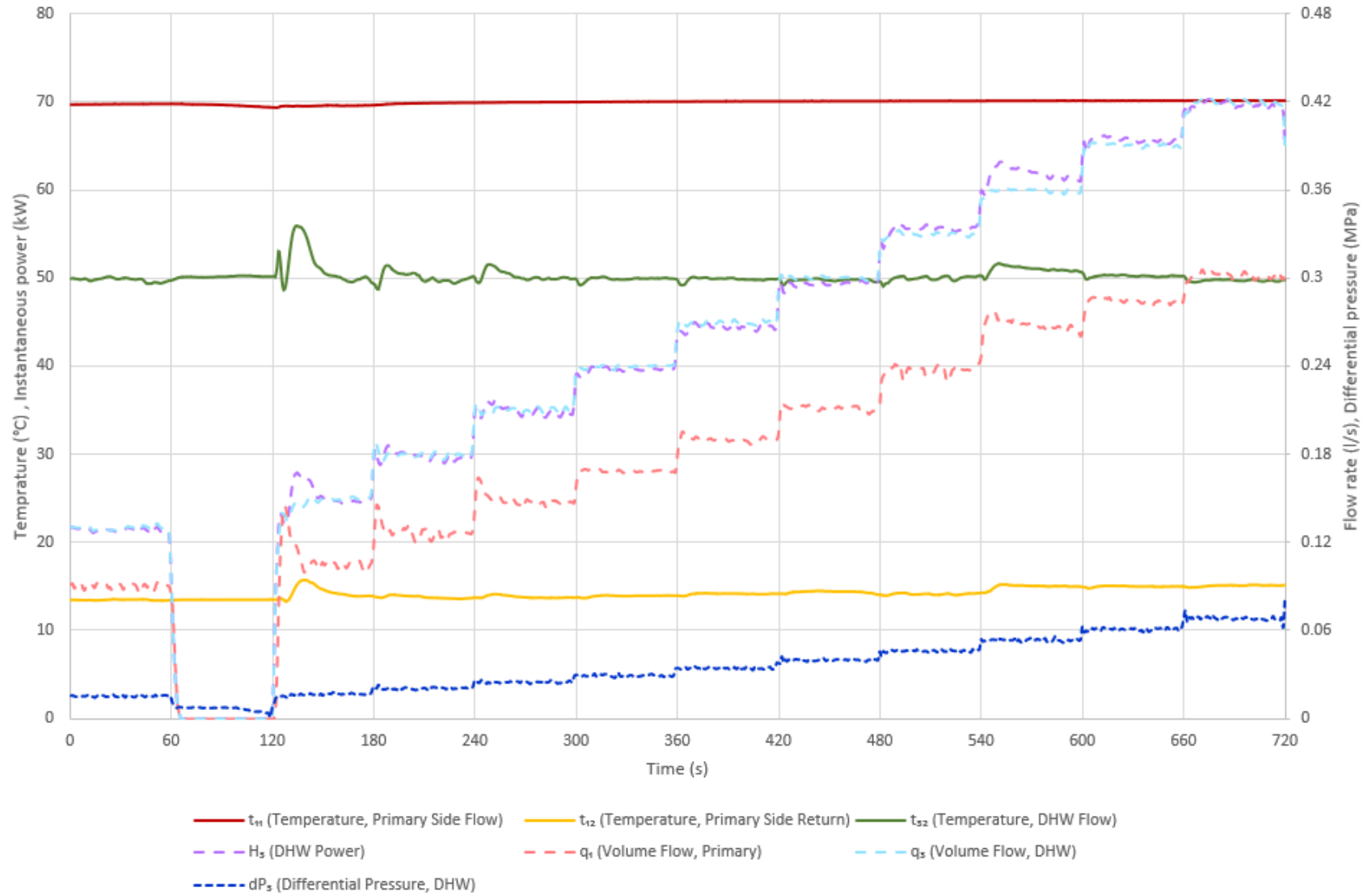

Figure 11 - Test 13a Key Metrics

## 8.8 Test 21a Information

8.8.1 Objective: To establish HIU performance during periods of no load, when operating in keep warm mode.

## 8.9 Test 21a Results

8.9.1 The keep warm operation is valid (based on Test 22a response time criteria).

8.9.2 The keep warm undergoes cycling (i.e.  $t_{11}$  varies by more than  $\pm 3$  °C during the final 3 hours of the test).

8.9.3 Performance criteria results can be seen in Table 26, test result data can be seen in Table 25 and key metrics can be found in Figure 12. Best practice criteria can be found in Table 27.

Table 25 - Module 7 Test 21a Results

Module 7 - Test 21a Results		
Parameter	Symbol	Result
Mean average volume flow, primary side	$q_1$ (l/s)	0.0005
Mean average of primary side power recorded during test	$H_1$ (kW)	0.02
Mean average electrical energy use	$W_{\text{electrical}}$ (W)	2.8
Mean average thermal energy use	$W_{\text{thermal}}$ (W)	18.5
Overall energy loss per day	(kWh)	0.511
Overall keep warm volume weighted avg. return temp	VWART (°C)	36

Table 26 - Module 7 Test 21a Performance Criteria

Module 7 - Test 21a Performance Criteria	
Performance Criteria, Fail if:	PASS/FAIL
VWART is above 44°C (to one decimal place)	Pass
Primary return temperature ( $t_{12}$ ) exceeds 55.0°C (to one decimal place) at any point, as this poses a scaling risk	Pass
Primary supply temperature to the HIU ( $t_{11}$ ) drops to below 39°C	Pass
HIU overall energy losses are greater than 1.000 kWh/day (to three decimal places)	Pass
Test 22a DHW temperature response time test fails (i.e. the HIU Keep Warm operation is not a valid Keep Warm)	Pass

Table 27 - Module 7 Test 21a Best Practice

<b>Module 7 – Test 21a – Best Practice Criteria</b>	
<b>Best Practice Criteria if:</b>	<b>Best Practice</b>
HIU overall energy losses are less than 0.700 kWh/day (to three decimal places).	Achieved

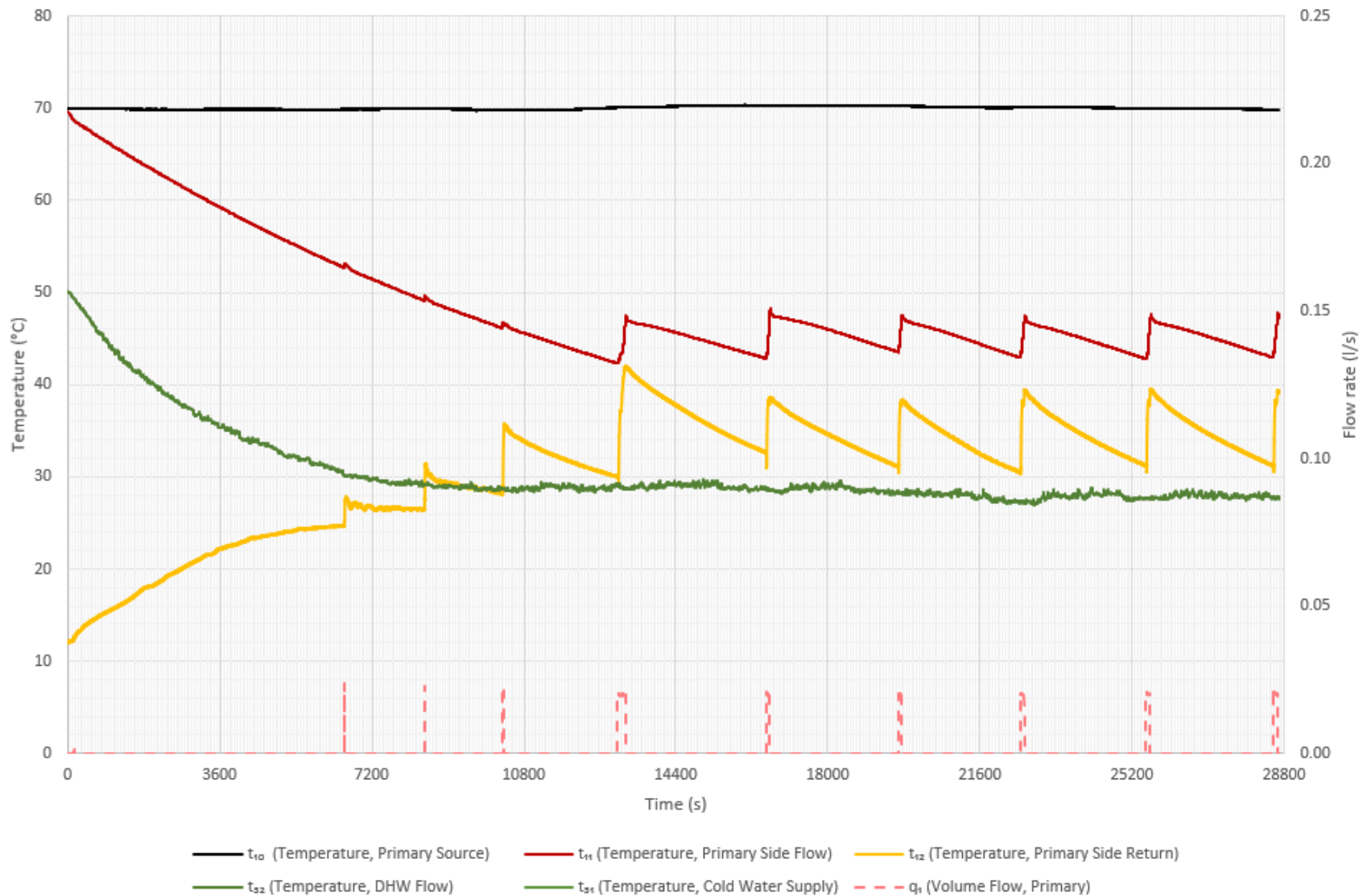

Figure 12 - Test 21a Key Metrics

## 8.10 Test 22a Information

8.10.1 Objective: To investigate DHW delivery time after a period of at least 8 hours keep warm only operation. This tests if the HIU can supply domestic hot water within an acceptable time of turning on the tap, which is a basic comfort requirement.

## 8.11 Test 22a Results

8.11.1 The keep warm operation is valid (based on response time criteria shown in Test 22 performance criteria).

8.11.2 Performance criteria results can be seen in Table 29, test result data can be seen in Table 28 and key metrics can be found in Figure 13. Best practice criteria can be found in Table 30.

Table 28 - Module 7 Test 22a Results

Module 7 - Test 22a Results		
Parameter	Symbol	Result
Time taken for $t_{32}$ to reach 45.0°C and not subsequently drop below 42.0°C	(s)	12
Number of consecutive seconds where $t_{32} > 55^\circ\text{C}$	(s)	0
Mean average volume flow, primary side	$q_1$ (l/s)	0.119

Table 29 - Module 7 Test 22a Performance Criteria

Module 7 - Test 22a Performance Criteria	
Performance Criteria, Fail if:	PASS/FAIL
DHW response time takes more than 15 seconds to reach 45.0°C (to one decimal place) at $t_{32}$ while not dropping below 42.0°C (to one decimal place) thereafter	Pass
DHW temperature ( $t_{32}$ ) exceeds 60.0°C (to one decimal place) for more than 1 second, as this poses a scalding risk	Pass
Primary return temperature ( $t_{12}$ ) exceeds 55.0°C (to one decimal place) at any point, as this poses a scaling risk	Pass

Table 30 - Module 7 Test 22a Best Practice

Module 7 – Test 22a – Best Practice Criteria	
Best Practice Criteria if:	Best Practice
DHW response time at $t_{32}$ is equal to or less than 10 seconds.	Not Achieved

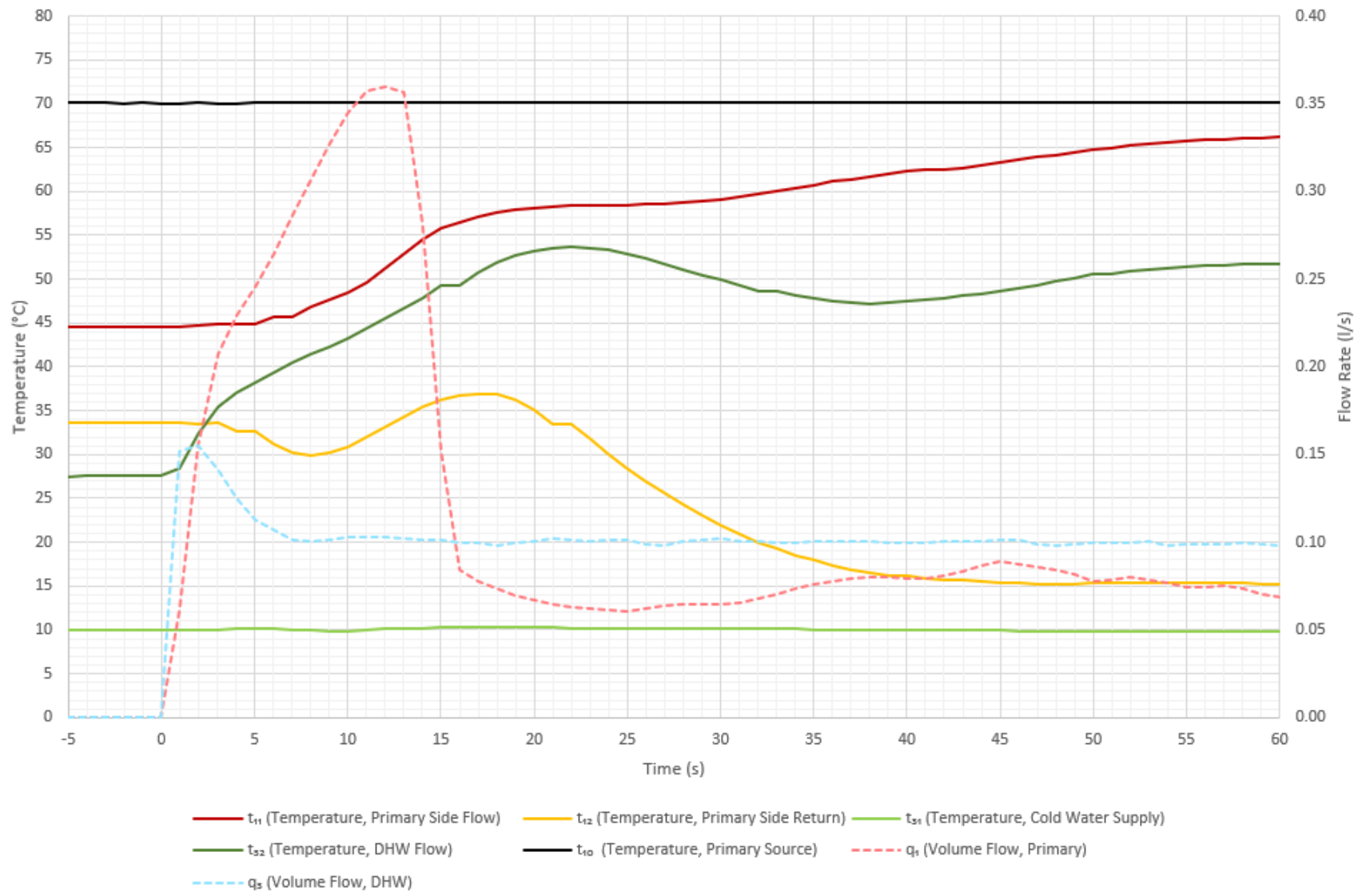

Figure 13 - Test 22a Key Metrics

## 9 TEST MODULE 8 – DHW, LOW TEMPERATURE, DH55-KWARM

### 9.1 Test Module 8 Information

9.1.1 Objective: To explore the performance of the HIU under changing loads, as would be the case in practical operation. Key performance criteria are speed and consistency of DHW delivery to the customer; DHW always staying at a safe temperature and the volume weighted average return temperature when supplying space heating or DHW.

9.1.2 The following set of tests are from Test Module 8 – Domestic Hot Water, Low Temperature, Keep Warm Hot Water Module 8 - DH55 – KWarm - V1-Rev002: 2026

Table 31 - Module 8 Tests

Module 8 Tests	
11b	DH/55C, DHW only, 50°C DHW, variable dP
12b	DH/55C, DHW Low Flow, 50°C DHW, 50kPa
12d	DH/55C, DHW Low Flow, 50°C DHW, 200kPa
13b	DH/55C, DHW Load Test, 50°C DHW
21b	DH/55C, DHW Keep Warm, 50°C DHW
22b	DH/55C, DHW Keep Warm Response Time, 50°C DHW

### 9.2 Test 11b Information

9.2.1 Objective: To investigate the performance of the HIU when delivering DHW, at a range of flow rates and differential pressures, given a 55°C primary flow temperature. The test investigates HIU operation in terms of DHW delivery and impacts on primary heat network return temperatures.

### 9.3 Test 11b Results

9.3.1 Performance criteria results can be seen in Table 33, test result data can be seen in Table 32 and key metrics can be found in Figure 14. Best practice criteria can be found in Table 34.

Table 32 - Module 8 Test 11b Results

Module 8 - Test 11b Results			
Parameter	Symbol	Result	
Maximum and minimum values of $t_{32}$ when there is DHW flow	$t_{32}$ (°C)	51.0	46.0
Number of consecutive seconds where $t_{32} > 55^{\circ}\text{C}$	(s)	0	
Overall DHW Volume Weighted Avg. Return Temp	VWART (°C)	18	

Table 33 - Module 8 Test 11b Performance Criteria

Module 8 - Test 11b Performance Criteria	
Performance Criteria, Fail if:	PASS/FAIL
DHW temperature ( $t_{32}$ ) exceeds $60.0^{\circ}\text{C}$ (to one decimal place) for more than 1 second, as this poses a scalding risk	Pass
Primary return temperature ( $t_{12}$ ) exceeds $55.0^{\circ}\text{C}$ (to one decimal place) at any point, as this poses a scaling risk	Pass
VWART is above $25^{\circ}\text{C}$ (to one decimal place)	Pass
Average DHW temperature ( $t_{32}$ ) is not $50.0^{\circ}\text{C} \pm 1^{\circ}\text{C}$ (to one decimal place) for the final 150 seconds of each of the 180 second DHW flow periods	Pass
DHW temperature ( $t_{32}$ ) is not being maintained at $50.0^{\circ}\text{C} \pm 3^{\circ}\text{C}$ (to one decimal place) for $>150$ seconds of each of the DHW flow periods	Pass
DHW temperature ( $t_{32}$ ) drops below $45.0^{\circ}\text{C}$ (to one decimal place) for more than 5 consecutive seconds, as this would impact resident comfort	Pass

Table 34 - Module 8 Test 11b Best Practice

Module 8 – Test 11b – Best Practice Criteria	
Best Practice Criteria if:	Best Practice
VWART is less than or equal to $19^{\circ}\text{C}$ (to one decimal place)	Achieved
DHW temperature ( $t_{32}$ ) is being maintained at $50.0^{\circ}\text{C} \pm 2^{\circ}\text{C}$ throughout periods of DHW flow	Not Achieved
DHW temperature ( $t_{32}$ ) doesn't drop below $45.0^{\circ}\text{C}$ (to one decimal place) for more than 2 consecutive seconds	Achieved

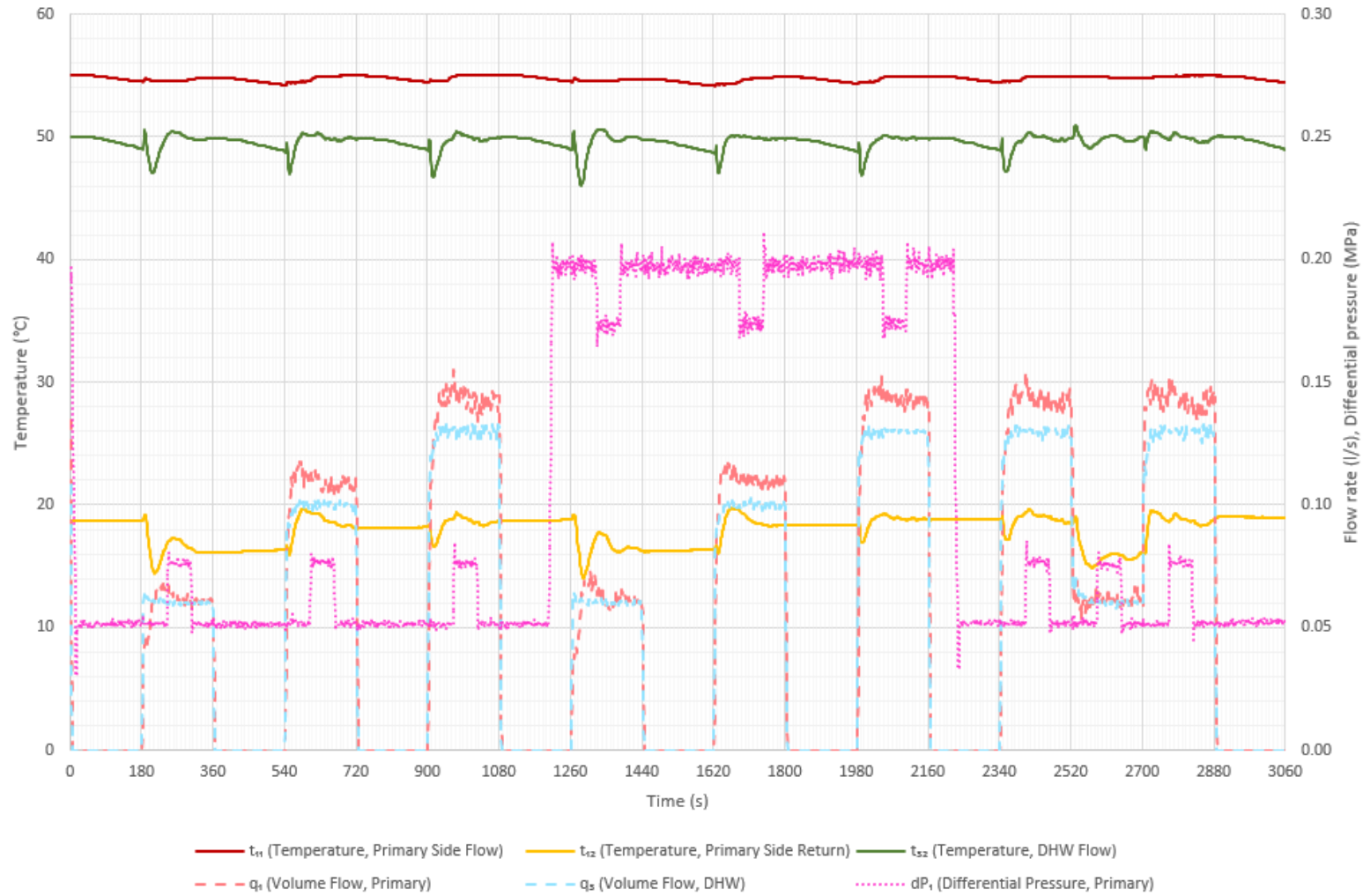

Figure 14 - Test 11b Key Metrics

#### 9.4 Test 12b / 12d Information

- 9.4.1 Objective: To investigate the stability of DHW temperature at low flow rates. During operation, domestic hot water is sometimes drawn off at extremely low flow rates. Test 12 investigates the ability of the system to meet this condition by measuring the temperature at test point  $t_{32}$  at a flow rate of 0.02 l/s.
- 9.4.2 Test 12b performs the low flow test at 50kPa differential pressure
- 9.4.3 Test 12d performs the low flow test at 200kPa differential pressure

#### 9.5 Test 12b / 12d Results

- 9.5.1 The HIU was able to deliver DHW at low flow rate above 45.0°C at the end of the 180 second period of low flow DHW.
- 9.5.2 The HIU was able to deliver stable DHW flow temperature (at  $t_{32}$ ), defined as ability to maintain 50.0 ±3.0°C (1 decimal place) during the last 60 seconds of the test.
- 9.5.3 Performance criteria results can be seen in Table 36, test result data can be seen in Table 35 and key metrics can be found in Figure 15 and Figure 16. Best practice criteria can be found in Table 37.

Table 35 - Module 8 Test 12 Results

Module 8 - Test 12 Results					
Parameter	Symbol	12b Result		12d Result	
Maximum and minimum values of $t_{32}$ when there is low DHW flow	$t_{32}$ (°C)	53.3	49.8	53.4	49.8
Number of consecutive seconds where $t_{32} > 55^{\circ}\text{C}$	(s)	0		0	

Table 36 - Module 8 Test 12 Performance Criteria

Module 8 - Test 12 Performance Criteria	
Performance Criteria, Fail if:	PASS/FAIL
DHW temperature ( $t_{32}$ ) exceeds 60.0°C (to one decimal place) for more than 1 second, as this poses a scalding risk	Pass
Primary return temperature ( $t_{12}$ ) exceeds 55.0°C (to one decimal place) at any point, as this poses a scaling risk	Pass
DHW temperature ( $t_{32}$ ) is not maintained at 50°C ±3°C (to one decimal place) for more than 60 seconds	Pass

Table 37 - Module 8 Test 12 Best Practice

<b>Module 8 – Test 12 – Best Practice Criteria</b>	
<b>Best Practice Criteria if:</b>	<b>Best Practice</b>
DHW temperature (t32) is maintained at 50°C ±2°C (to one decimal place) throughout the test for both test 12b and 12d	Not Achieved

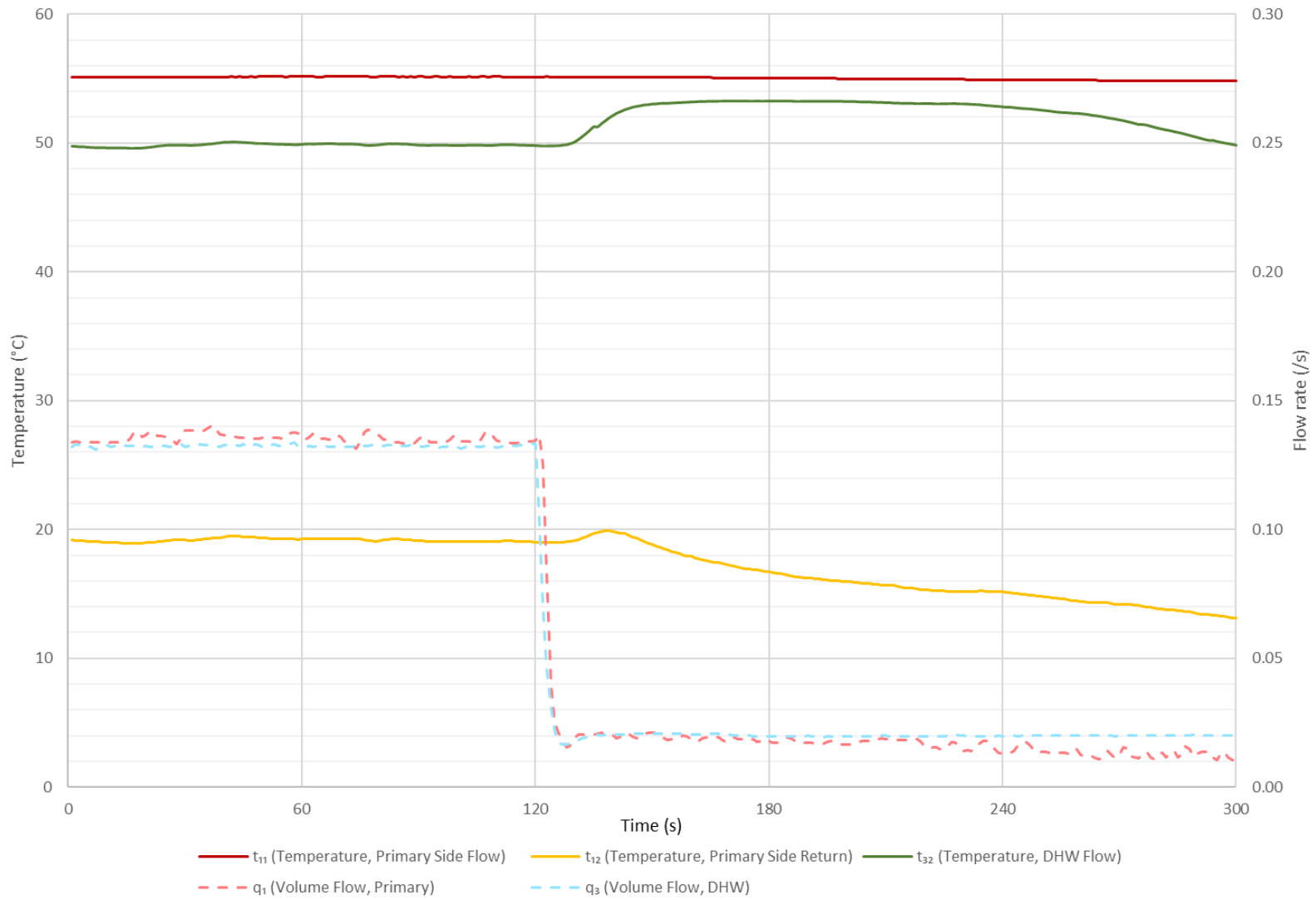

Figure 15 - Test 12b Key Metrics

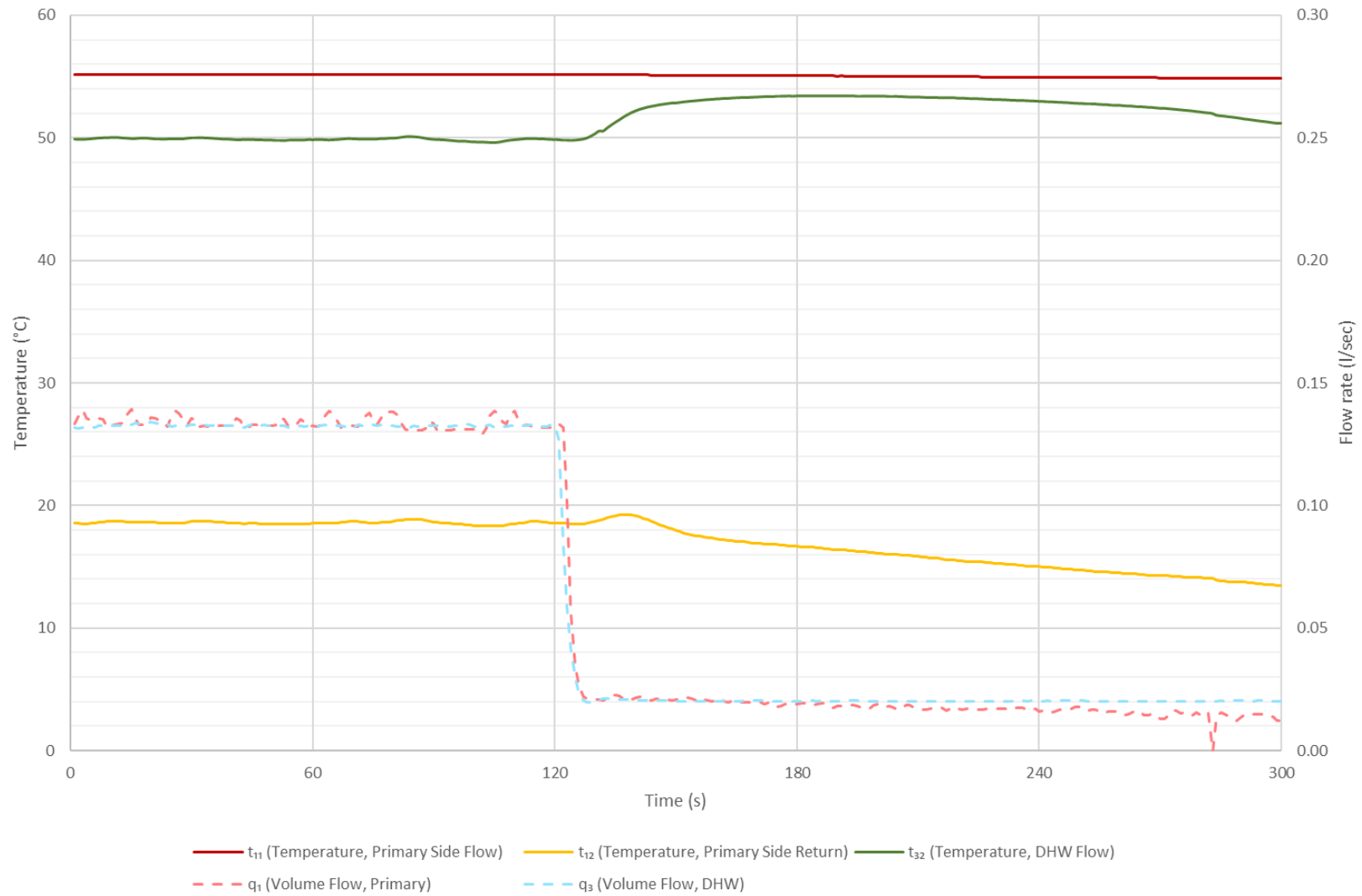

Figure 16 - Test 12d Key Metrics

## 9.6 Test 13b Information

9.6.1 Objective: To measure the maximum heat output (kW) and flow (l/sec) DHW output that can be delivered from the HIU. The HIU shall be set to deliver 50°C and the maximum DHW power output shall be measured with a flow step change and the peak value recorded when the DHW flow temperature is above 45°C.

## 9.7 Test 13b Results

9.7.1 The maximum DHW heat output was recorded as 57.1 kW, with a measured flow rate of 0.390 l/s, when producing minimum DHW at 45°C or above. (Temperature achieved at final step 45.1°C).

9.7.2 The recorded DHW line pressure drop across the HIU was 61 kPa.

9.7.3 The number of consecutive seconds where  $t_{32} > 55^{\circ}\text{C}$  was 0 seconds.

9.7.4 Performance criteria results can be seen in Table 38, test result data can be seen in Table 39, key metrics can be found in Figure 17.

Table 38 - Module 8 Test 13b Performance Criteria

<b>Module 8 - Test 13b Performance Criteria</b>	
<b>Performance Criteria, Fail if:</b>	<b>PASS / FAIL</b>
DHW (at $t_{32}$ ) is not maintained at $50^{\circ}\text{C} \pm 1.0^{\circ}\text{C}$ (to one decimal place) at 0.13 l/s flow rate, as the HIU must be able to produce DHW to the target temperature at a moderate load	Pass
DHW temperature ( $t_{32}$ ) exceeds $60.0^{\circ}\text{C}$ (to one decimal place) for more than 1 second, as this poses a scalding risk	Pass
Primary return temperature ( $t_{12}$ ) exceeds $55.0^{\circ}\text{C}$ (to one decimal place) at any point, as this poses a scaling risk	Pass

Table 39 - Module 8 Test 13b Results

Module 8 - Test 13b Results – Mean Average of Last 10 Seconds											
Parameter	Symbol	0.15 l/s (25kW)	0.18 l/s (30kW)	0.21 l/s (35kW)	0.24 l/s (40kW)	0.27 l/s (45kW)	0.30 l/s (50kW)	0.33 l/s (55kW)	0.36 l/s (60kW)	0.39 l/s (65kW)	0.42 l/s (70kW)
Temperature, primary side flow connection	$t_{11}$ (°C)	54.9	55.0	55.1	55.1	55.1	55.1	55.1	55.1	<b>55.1</b>	55.1
Temperature, primary side return connection	$t_{12}$ (°C)	18.8	19.2	19.2	19.5	19.7	19.6	19.4	18.2	<b>17.1</b>	16.2
Volume flow, primary side	$q_1$ (l/s)	0.165	0.201	0.237	0.271	0.302	0.331	0.355	0.360	<b>0.359</b>	0.359
Arithmetic mean of primary side power recorded during test	$H_1$ (kW)	25.0	30.1	35.5	40.2	44.7	49.2	53.0	55.5	<b>57.0</b>	58.4
Temperature, cold water supply	$t_{31}$ (°C)	10.3	10.3	9.4	9.6	9.8	9.8	9.9	9.9	<b>10.1</b>	10.1
Temperature, domestic hot water flow from HIU	$t_{32}$ (°C)	49.7	49.9	49.9	49.7	49.3	48.9	48.3	46.8	<b>45.1</b>	43.4
Volume flow, domestic hot water	$q_3$ (l/s)	0.151	0.181	0.212	0.242	0.270	0.302	0.330	0.361	<b>0.390</b>	0.419
Differential pressure, domestic hot water across HIU	$dP_3$ (kPa)	17	21	25	31	36	40	47	54	<b>61</b>	68
Arithmetic mean of DHW power recorded during test	$H_3$ (kW)	24.8	30.0	35.8	40.4	44.7	49.3	53.0	55.5	<b>57.1</b>	58.3

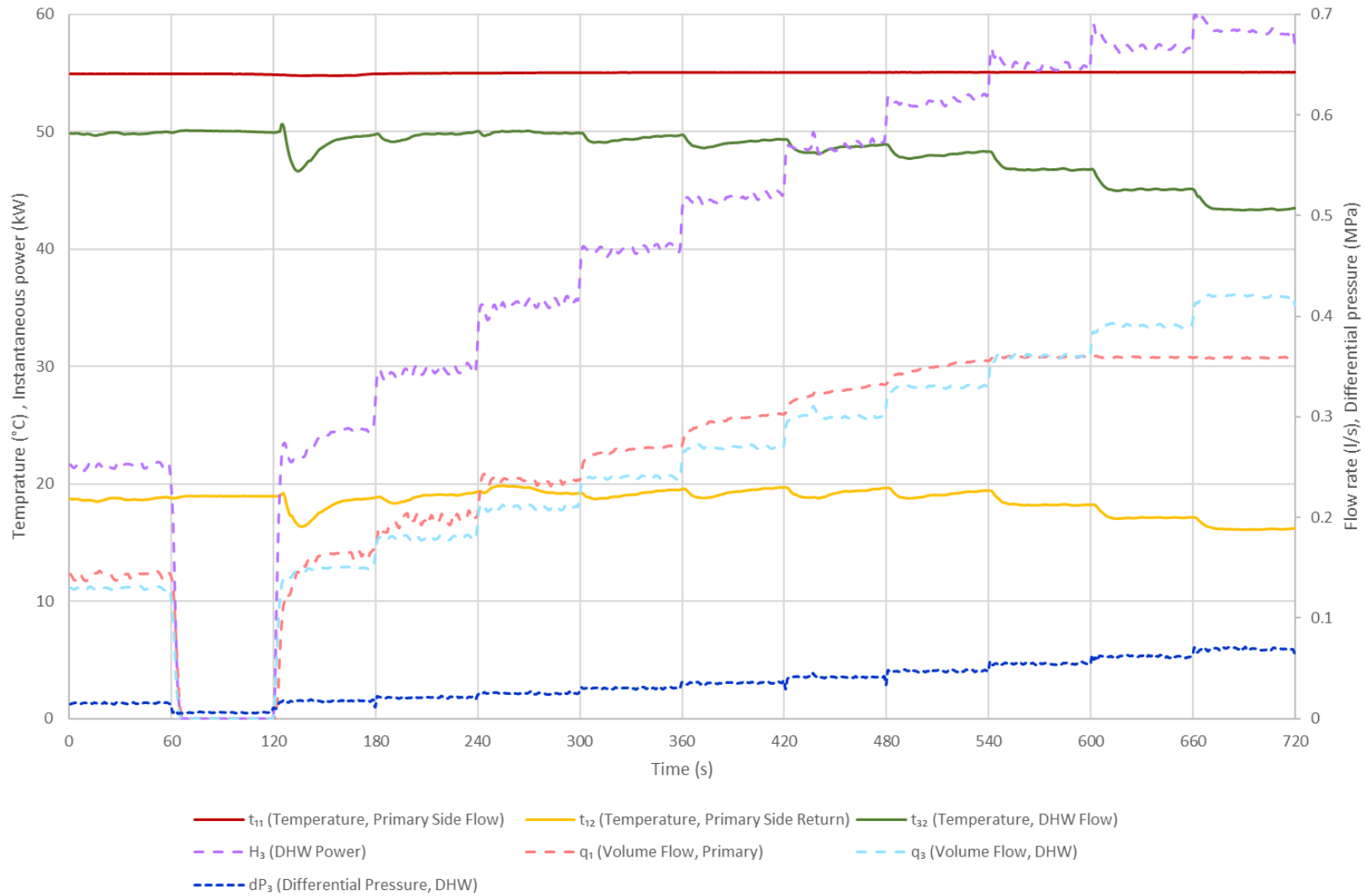

Figure 17 - Test 13b Key Metrics

## 9.8 Test 21b Information

9.8.1 Objective: To establish HIU performance during periods of no load, when operating in keep warm mode.

## 9.9 Test 21b Results

9.9.1 The keep warm operation is valid (based on Test 22b response time criteria).

9.9.2 The keep warm undergoes cycling (i.e.  $t_{11}$  varies by more than  $\pm 3$  °C during the final 3 hours of the test).

9.9.3 Performance criteria results can be seen in Table 41, test result data can be seen in Table 40 and key metrics can be found in Figure 18. Best practice criteria can be found in Table 42.

Table 40 - Module 8 Test 21b Results

Module 8 - Test 21b Results		
Parameter	Symbol	Result
Mean average volume flow, primary side	$q_1$ (l/s)	0.0013
Mean average of primary side power recorded during test	$H_1$ (kW)	0.03
Mean average electrical energy use	$W_{\text{electrical}}$ (W)	2.8
Mean average thermal energy use	$W_{\text{thermal}}$ (W)	29.7
Overall energy loss per day	(kWh)	0.781
Overall Keep Warm Volume Weighted Avg. Return Temp	VWART (°C)	40

Table 41 - Module 8 Test 21b Performance Criteria

Module 8 - Test 21b Performance Criteria	
Performance Criteria, Fail if:	PASS/FAIL
VWART is above 48°C (to one decimal place)	Pass
Primary return temperature ( $t_{12}$ ) exceeds 55.0°C (to one decimal place) at any point, as this poses a scaling risk	Pass
Primary supply temperature to the HIU ( $t_{11}$ ) drops to below 39°C	Pass
HIU overall energy losses are greater than 1.000 kWh/day (to three decimal places)	Pass
Test 22b DHW temperature response time test fails (i.e. the HIU Keep Warm operation is not a valid Keep Warm)	Pass

Table 42 - Module 8 Test 21b Best Practice

<b>Module 8 – Test 21b – Best Practice Criteria</b>	
<b>Best Practice Criteria if:</b>	<b>Best Practice</b>
HIU overall energy losses are less than 0.700 kWh/day (to three decimal places)	Not Achieved

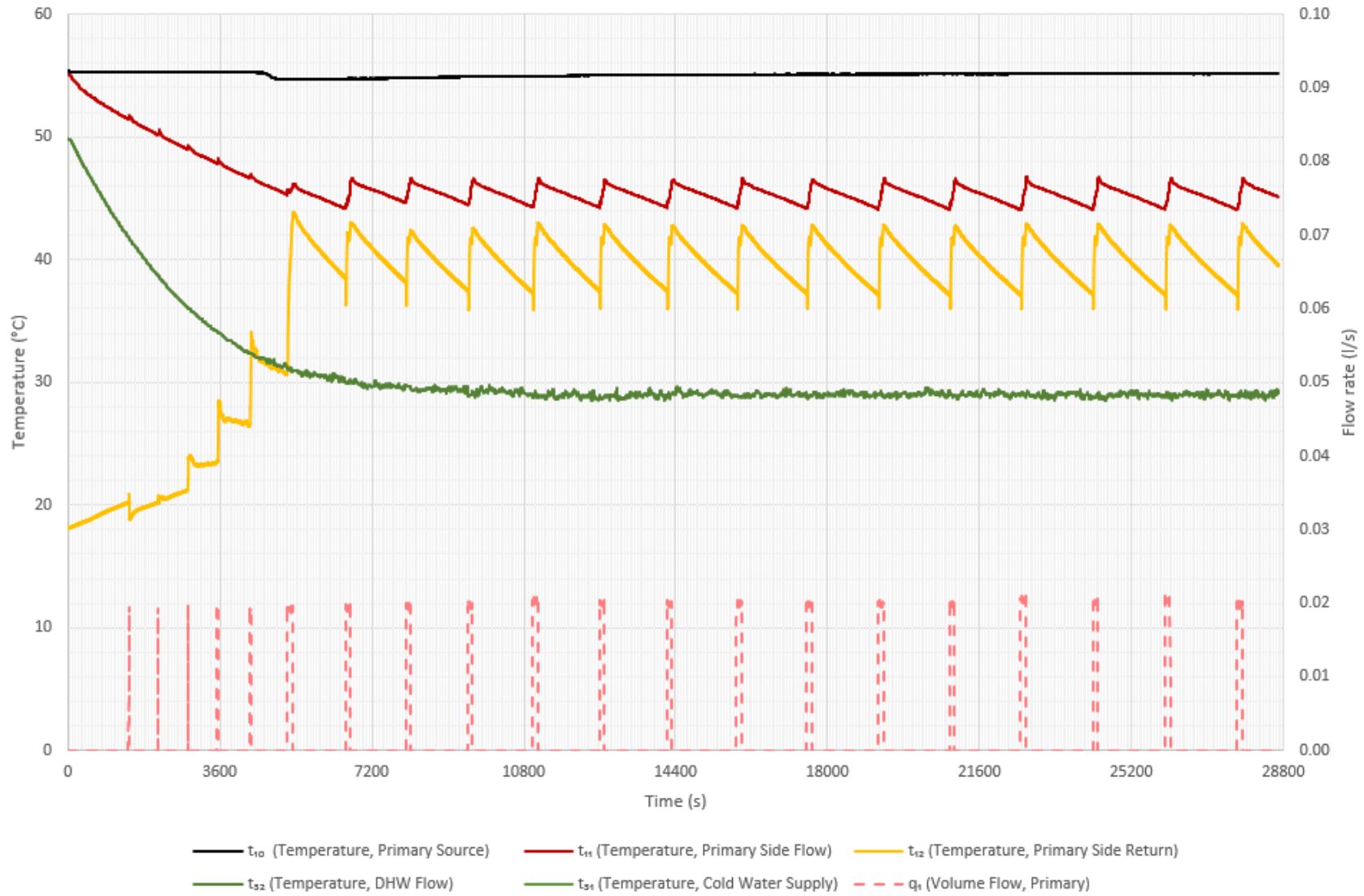

Figure 18 - Test 21b Key Metrics

## 9.10 Test 22b Information

9.10.1 Objective: To investigate DHW delivery time after a period of at least 8 hours keep warm only operation. This tests if the HIU can supply domestic hot water within an acceptable time of turning on the tap, which is a basic comfort requirement.

## 9.11 Test 22b Results

9.11.1 The keep warm operation is valid (based on response time criteria shown in Test 22 performance criteria).

9.11.2 Performance criteria results can be seen in Table 44, test result data can be seen in Table 43 and key metrics can be found in Figure 19. Best practice criteria can be found in Table 45.

Table 43 - Module 8 Test 22b Results

Module 8 - Test 22b Results		
Parameter	Symbol	Result
Time taken for $t_{32}$ to reach 45.0°C and not subsequently drop below 42.0°C	(s)	14
Number of consecutive seconds where $t_{32} > 55^\circ\text{C}$	(s)	0
Mean average volume flow, primary side	$q_1$ (l/s)	0.149

Table 44 - Module 8 Test 22b Performance Criteria

Module 8 - Test 22b Performance Criteria	
Performance Criteria, Fail if:	PASS/FAIL
DHW response time takes more than 15 seconds to reach 45.0°C (to one decimal place) at $t_{32}$ while not dropping below 42.0°C (to one decimal place) thereafter	Pass
DHW temperature ( $t_{32}$ ) exceeds 60.0°C (to one decimal place) for more than 1 second, as this poses a scalding risk	Pass
Primary return temperature ( $t_{12}$ ) exceeds 55.0°C (to one decimal place) at any point, as this poses a scaling risk	Pass

Table 45 - Module 8 Test 22b Best Practice

Module 8 – Test 22b – Best Practice Criteria	
Best Practice Criteria if:	Best Practice
DHW response time at $t_{32}$ is equal to or less than 10 seconds	Not Achieved

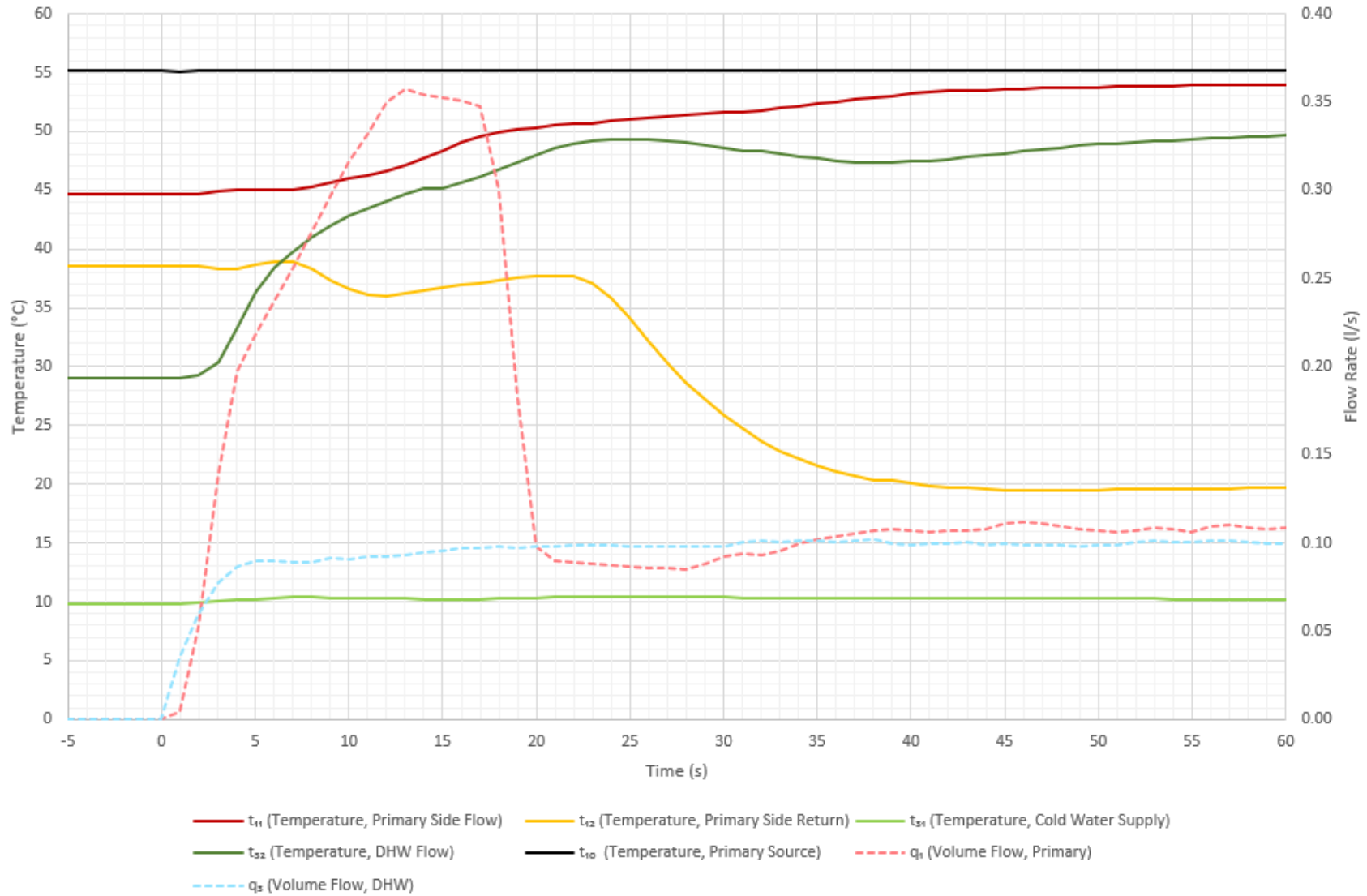

Figure 19 - Test 22b Key Metrics

## 10 CONCLUSIONS

All conclusions, opinions and interpretations indicated in this report are outside the scope of Enertek's UKAS accreditation.

- 10.1.1 The HIU has passed the requirements of the BESA Technical Standard for UK HIU Test Regime, V3-Rev002: March 2026 – Modules 1, 2, 7 and 8.

## 11 EQUIPMENT AND INSTRUMENT LIST

EQUIPMENT NAME	ID NUMBER	CERTIFICATE NUMBER	MEASUREMENT UNCERTAINTY K=2	CALIBRATION DATE	CALIBRATION DUE
Cold Water Supply Probe T <sub>31</sub>	PRT 6035	CAL-001085	± 0.070 °C	25/09/2025	25/09/2026
DHW Outlet Probe T <sub>32</sub>	PRT 6036	CAL-001086	± 0.070 °C	25/09/2025	25/09/2026
Primary Inlet Probe T <sub>11</sub>	PRT 6034	CAL-001084	± 0.070 °C	25/09/2025	25/09/2026
Primary Return Probe T <sub>12</sub>	PRT 6033	CAL-001083	± 0.070 °C	25/09/2025	25/09/2026
SH Flow Probe T <sub>22</sub>	PRT 6031	CAL-001080	± 0.070 °C	25/09/2025	25/09/2026
SH Return Probe T <sub>21</sub>	PRT 6032	CAL-001081	± 0.072 °C	25/09/2025	25/09/2026
Primary Flow T <sub>10</sub>	PRT 5008	CAL-001070	± 0.076 °C	25/09/2025	25/09/2026
Ambient Temperature	PRT 4607	CAL-000873	± 0.136 °C	25/09/2025	25/09/2026
Flow Meter	FM 601	K59426FW	± 0.0112 l/sec	19/09/2025	19/09/2026
Flow Meter	FM 602	K59425FW	± 0.0132 l/sec	22/09/2025	22/09/2026
Flow Meter	FM 603	K59427FW	± 0.0090 l/sec	22/09/2025	22/09/2026
Flow Meter	FM 605	K59428FW	± 0.0040 l/sec	23/09/2025	23/09/2026
Pressure Transducer	PT 083	K59419P	± 2.7 kPa	18/09/2025	18/09/2026
Pressure Transducer	PT 084	K59420P	± 8.1 kPa	18/09/2025	18/09/2026
Pressure Transducer	PT 085	K59421P	± 3.6 kPa	18/09/2025	18/09/2026
Pressure Transducer	PT 086	K59422P	± 4.0 kPa	18/09/2025	18/09/2026
Pressure Transducer	PT 087	K59423P	± 3.8 kPa	18/09/2025	18/09/2026
Pressure Transducer	PT 088	K59424P	± 4.93 kPa	18/09/2025	18/09/2026
Power Meter	PM 1022	TH120471	± 0.09 W	05/09/2025	05/09/2026
Pipe	PIPE 001	-	-	10/2025	10/2026

The reported expanded uncertainty is based on a standard uncertainty by a coverage factor  $K = 2$ , providing a level of confidence of approximately 95 %. The uncertainty evaluation has been carried out in accordance with BS EN ISO/IEC 17025:2017 requirements.

## 12 APPENDIX A

### 12.1 VWART Calculations for Modules 1 & 7

	VWART (°C)	Volume (m <sup>3</sup> )		VWART (°C)
DHW	13	24.9	Summer	21
Standby	36	13.8	Winter	28
Space Heating	35	33.7	Overall	24

	DHW Draw Test Results			Post DHW Draw (60 seconds)	
	Power (W)	Primary Flow (m <sup>3</sup> /hr)	VWART (°C)	Primary Volume (L)	VWART (°C)
Low	9734.6	0.1	12	0.29	12
Medium	16173.8	0.2	13	0.07	13
High	20963.1	0.3	14	0.06	13

DHW Draw Volumes pa		
kWh pa	Hours	Volume pa (m <sup>3</sup> )
729	74.89	10.5
297	18.36	4.6
444	21.18	6.8

Post DHW Draw Volumes pa	
Events pa	Volume pa (m <sup>3</sup> )
10000	2.911
660	0.049
300	0.018

Standby Test Results	
Primary Flow (m <sup>3</sup> /hr)	VWART (°C)
0.002	36

Standby Volumes pa	
Hours	Volume pa (m <sup>3</sup> )
7592	13.765

	Space Heating					
	Power (W)	Primary Flow (m <sup>3</sup> /hr)	VWART (°C)	kWh pa	Hours	Volume pa (m <sup>3</sup> )
0.5kW	526	0.008	34	98	186	1.56
1kW	1092	0.025	35	787	720	18.18
4kW	3932	0.095	36	565	144	13.60

12.1.1 It should be noted that all VWART figures are to within  $\pm 2^{\circ}\text{C}$  tolerance.

## 12.2 VWART Calculations for Modules 2 & 8

	VWART (°C)	Volume (m <sup>3</sup> )
DHW	17	38.0
Standby	40	35.7
Space Heating	35	62.0

	VWART (°C)
Summer	28
Winter	32
Overall	30

	DHW Draw Test Results			Post DHW Draw (60 seconds)	
	Power (W)	Primary Flow (m <sup>3</sup> /hr)	VWART (°C)	Primary Volume (L)	VWART (°C)
Low	9687.4	0.2	17	0.44	16
Medium	16023.0	0.4	18	0.12	18
High	20792.3	0.5	19	0.10	19

DHW Draw Volumes pa		
kWh pa	Hours	Volume pa (m <sup>3</sup> )
729	75.25	15.9
297	18.54	7.1
444	21.35	10.5

Post DHW Draw Volumes pa	
Events pa	Volume pa (m <sup>3</sup> )
10000	4.405
660	0.082
300	0.029

Standby Test Results	
Primary Flow (m <sup>3</sup> /hr)	VWART (°C)
0.005	40

Standby Volumes pa	
Hours	Volume pa (m <sup>3</sup> )
7514	35.677

	Space Heating					
	Power (W)	Primary Flow (m <sup>3</sup> /hr)	VWART (°C)	kWh pa	Hours	Volume pa (m <sup>3</sup> )
0.5kW	529	0.022	34	98	185	4.03
1kW	975	0.041	35	787	807	32.77
4kW	4133	0.184	36	565	137	25.16

12.2.1 It should be noted that all VWART figures are to within  $\pm 2^{\circ}\text{C}$  tolerance.

## 13 APPENDIX B

### 13.1 Appliance Documentation

13.1.1 The details of the appliance documentation are given in Table 46 below.

Table 46 - Appliance Documentation

#	Component:	Document Submitted (Y/N):	Manufacturer and type:
1	Space Heating Heat Exchanger	Y	Swep E8T*30
2	Domestic Hot Water Heat Exchanger	Y	Danfoss XB05 - 70
3	Controller for Space Heating and Hot Water Heating	Y	Sensience HIU Controller
4	Control Valve and Actuator for Space Heating	Y	Frese Integra Compact
5	Space Heating Strainer	Y	Tongsheng Brass Co. ¾" M x F Isolation Valve with Strainer
6	Control Valve and Actuator for Hot Water Heating	Y	Frese Integra Compact
7	Temperature Sensors	Y	Tasseron
8	Domestic Hot Water Isolating Valve	Y	BONOMI Series S90 ¾" M x F
9	Primary Side Strainer	Y	Tongsheng Brass Co. ¾" M x F Isolation Valve with Strainer
10	Drain Valves	Y	Tongsheng Brass Co. ½" PN16
11	Vent Valve	-	-
12	Circulation Pump	Y	Grundfos UPM3 15-70, 130 Auto
13	Heat Meter	Y	Kamstrup MULTICAL 603
14	Domestic Hot Water Flow Sensor	Y	Resideo C7195B
15	Pipes	Y	SS 304 – Primary & Heating SS 316L - MCW & DHW
16	Connections	Y	KVM Various Brass
17	Joints	Y	KVM Various Brass
18	Gaskets	Y	KLINGERSIL® C-4430 NBR/fibre washer Centellen® HD 3822 NBR/fibre washer
19	O Rings	-	-
20	Pressure Sensor	-	-

21	Expansion Vessel	Y	CIMM RP220 x 550 8 Litre
22	Insulation	Y	ARPRO 5135 EPP Casing
A1	Commissioning Guide	Y	vTherme° installation, commissioning and maintenance manual Version No:001
A2	Operation Guide	Y	vTherme° installation, commissioning and maintenance manual Version No:001
A3	Declaration of Conformity	Y	See Section 14.1
A4	Full Parameter List	N	Keep warm set point 46°C
A5	Maximum Primary Static Operating Differential Pressure	N	16 bar Static 6 bar differential
	Software Version	N	D7
	Model Name and Type Number	Y	vTherm°e HI / HWI / 004 / S
	Serial Number	Y	102000-000001
	Any other components stated by manufacturer	-	-

## 13.2 Appliance Photographs



Figure 20 - HIU with Outer Case Fitted



Figure 21 - HIU with Outer Case Removed

**VITAL  
ENERGI**

Century House, Roman Road, Blackburn, Lancashire BB1 2LD

**Site Name: BESA HIU 1**
**HIU Type: Vital Energi vTherm°e HI / HWI / 004 / S**
**Item No.: 102000-000001**
**Year / Month of Manufacture: 2025 / 11**

	Primary (District Heating)		Secondary (Heating)		Secondary (Hot Water)	
<b>Max. Working Pressure</b>	16	Bar	2.5	Bar	10	Bar
	1.6	MPa	0.25	MPa	1	MPa
<b>Max. Temperature</b>	90	°C	80	°C	60	°C
<b>Capacity</b>	-		10	kW	55	kW
<b>Flow Rate (DHW only)</b>	844	l/h	0.430	m <sup>3</sup> /h	1.181	m <sup>3</sup> /h
<b>Flow Rate (Heating only)</b>	268					
<b>Temperatures</b>	70 / 38	°C	55 / 35	°C	50 / 10	°C
<b>Nominal Pressure</b>			PN16			
<b>Min. Storage Temperature</b>			5°C			
<b>Electrical Requirements</b>			230V / 50Hz / 5A			

Figure 22 - Nameplate with Model Details and Serial Number

# 14 APPENDIX C

## 14.1 UK Declaration of Conformity



### Declaration of Conformity (DOC)



**Manufacturer:** Vital Energi Utilities Limited, Century House, Roman Road, Blackburn. BB1 2LD

**Product:** vTherm<sup>e</sup> - Electronically Controlled HIU (Hydraulic Interface Unit) for the transfer of energy to Domestic Hot Water and Heating systems.

The product complies with the following directives and regulations:

Product Name	Directive	Documentation	Compliance
vTherm <sup>e</sup> Wireless Integrated Heat Interface Unit (HIU) with Bluetooth, Wi-Fi and NB-IoT	(LVD) 2014/35/EU	BS EN 60335-1: 2012 + A11:2014 + A13:2017	Compliance demonstrated by: Kiwa report No. R20-5024
	(EMC) 2014/30/EU	EN 55014-1:2017 EN 55014-2:2015 CAT IV EN 61000-3-2:2014 EN 61000-3-3:2013	Compliance demonstrated by: Kiwa report. No. R20-5038
		ETSI EN 301 489-17 v3.2.4 ETSI EN 301 489-52 v1.1.2 ETSI EN 301 489-1 v2.2.3 EN 55014-1:2017 + A11:2020 EN 55014-2:2015 CAT IV	Compliance demonstrated by: Kiwa report. No. R21-5595

**Manufacturer's Authorised Representatives:**

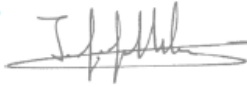
Name: Ian Spencer Position: Technical Director Date: 01/02/2026 Signature: 	Name: James Gallacher Position: Quality Manager Date: 01/02/2026 Signature: 
---	---

**Product Data Label:**



Figure 23 - UK Declaration of Conformity

### 14.3 Water Regulation 4 Certificate

Reg4 certificate to be added.

Figure 24 - Water Reg 4 Certification

## 15 BIBLIOGRAPHY

- [1] *BESA (Building Engineering Services Association) UK HIU (Heat Interface Unit) Test regime Technical Specification, V3-Rev002: March 2026*
- [2] *Technical Standard for UK HIU Test Regime - Space Heating, High Temperature, Indirect HEATING MODULE 1-DH70 Indirect, V1-Rev002: March 2026*
- [3] *Technical Standard for UK HIU Test Regime - Space Heating, Low Temperature, Indirect HEATING MODULE 2-DH55 Indirect, V1-Rev002: March 2026*
- [4] *Technical Standard for UK HIU Test Regime - Domestic Hot Water, High Temperature, Keep Warm HOT WATER MODULE 7-DH70-KWarm, V1-Rev002: March 2026*
- [5] *Technical Standard for UK HIU Test Regime - Domestic Hot Water, Low Temperature, Keep Warm HOT WATER MODULE 8-DH55-KWarm, V1-Rev002: March 2026*

Report Issue No	Reason for Report Update
1	Original issue
2	Test 12a data misaligned adjusted alignment and reassessed max temperature value. Updated results in table 12a
3	Technical Information Changes of Standard names and revisions
4	Formatting changes

THIS PAGE IS INTENTIONALLY LEFT BLANK

THIS PAGE IS INTENTIONALLY LEFT BLANK



1 Malmo Road  
Sutton Fields  
Kingston upon Hull, HU7 0YF

+44 (0) 1482 877500  
[enertekinternational.com](http://enertekinternational.com)  
Registered in England No. 2262638

