

Project Number: E4360
Project Title: BESA Testing for Greenstar HIU KE plus
Client: Worcester Bosch
Client Address: Cotswold way
Warndon
Worcester
WR4 9SW
Date: 26 February 2020
Report Number: 1

Prepared By:

I. Williamson / Project Engineer



Approval By:



Howard Ruston / R&D Manager



This report is confidential to the client named on the front cover.

This report may be stored, transmitted or reproduced in full by the named client, however if the report is to be placed in the public domain or used for publicity / promotional purposes please inform a director of Enertek International Ltd.

The report must not be reproduced in part, edited, abridged or any extracts used for any purpose whatsoever without written permission from a director of Enertek International Ltd.

Any test results contained in this report apply only to the specific sample(s) tested as described in the report.

This report does not imply or indicate any element of commercial approval, recommendation or promotion by Enertek International Ltd.

CONTENTS

1	BRIEF	4
2	DEFINITIONS	5
3	TEST OBJECT	6
3.1	Appliance Details.....	6
3.2	Design Pressures	6
3.3	Design temperatures.....	6
4	TEST METHOD	7
4.1	Installation of Appliance	7
4.2	Test Regime.....	7
4.3	Measurement & Uncertainties	7
5	TEST RESULTS	12
5.1	Test 0 –Pressure Test	12
5.2	Test 1a to 1f – Space Heating 1-4 kW at 70 and 60 °C	12
5.3	Test 2a – DHW only at 70 °C	13
5.4	Test 2b – DHW only at 60 °C	13
5.5	Test 3c – Low Flow DHW at 70 °C	13
5.6	Test 3d – Low Flow DHW at 60 °C	13
5.7	Test 4a – Keep-warm at 70 °C	14
5.8	Test 4b – Keep-warm at 60 °C.....	14
5.9	Test 5a – DHW Response Time at 70 °C.....	15
5.10	Test 5b – DHW Response Time at 60 °C.....	15
5.11	Overall Scaling Risk Assessment.....	15
5.12	Test Summary	16
5.13	VWART Calculations	19
6	CONCLUSIONS	19
7	APPENDIX A	20
7.1	Key Metric Plots	20
7.2	Key Metric and VWART Summary	35
8	APPENDIX B	38
8.1	Appliance Documentation	38
8.2	Appliance Components	39
8.3	Appliance Photographs	40
8.4	Calibrations and uncertainties	42

LIST OF FIGURES

Figure 4.1 – EIL’s HIU Test Rig schematic	8
Figure 7.1 - Test 1a – Space Heating 1 kW at 70 °C	21
Figure 7.2 - Test 1b – Space Heating 2 kW at 70 °C	22
Figure 7.3 - Test 1c – Space Heating 4 kW at 70 °C	23
Figure 7.4 - Test 1d – Space Heating 1 kW at 60 °C	24
Figure 7.5 - Test 1e – Space Heating 2 kW at 60 °C	25
Figure 7.6 - Test 1f – Space Heating 4 kW at 60 °C	26
Figure 7.7 - Test 2a – DHW only at 70 °C	27
Figure 7.8 - Test 2b – DHW only at 60 °C	28
Figure 7.9 - Test 3c – Low Flow DHW at 70 °C	29
Figure 7.10 - Test 3d – Low Flow DHW at 60 °C	30
Figure 7.11 - Test 4a – Keep-warm at 70 °C	31
Figure 7.12 - Test 4b – Keep-warm at 60 °C	32
Figure 7.13 - Test 5a – DHW Response Time at 70 °C	33
Figure 7.14 - Test 5b – DHW Response Time at 60 °C	34
Figure 8.1 – Photograph of appliance with case off	40
Figure 8.2 – Photograph of appliance with case on	40
Figure 8-3 – Data Label	41

LIST OF TABLES

Table 3.1 – Appliance Details	6
Table 3.2 – Appliance Design Pressures	6
Table 3.3 – Appliance Design Temperatures	6
Table 4.1 – Setup of tests (extracted from BESA Test Regime)	9
Table 4.2 – Test Reporting, adapted from BESA Test Regime	10
Table 5.1 - Test Results for Space Heating Tests 1a to 1f	12
Table 5.2 - Overall Scaling Risk Assessment	15
Table 5.3 – High Temperature VWART Calculations	19
Table 5.4 – Low Temperature VWART Calculations	19
Table 7.1 - key metrics of Low Temperature Package	36
Table 7.2 - key metrics of High Temperature Package	37
Table 8.1 – Documentation Supplied	38
Table 8.2 – Appliance Components details	39
Table 8.3 - EIL Equipment Calibration and Uncertainties	42

1 BRIEF

- 1.1.1 Enertek international Limited (EIL), were contracted to receive, install and commission a production sample, Greenstar HIU KE Plus with heat meter on behalf of Worcester Bosch.
- 1.1.2 To carry out the work involved to evaluate the performance of Domestic Hot Water (DHW) and Space Heating (SH) in accordance with the BESA UK HIU Test regime Technical Specification, Rev-009 requirements, a publicly available online test regime. This is here-on referred to as the Test Regime throughout this document.
- 1.1.3 To provide a report detailing the tests carried out and generated results in accordance with the Test Regime criteria, including calculations for Volume Weighted Average Return Temperatures (VWART).

2 DEFINITIONS

2.1.1 The following definitions and abbreviations have been used within this report:

Symbol	Description	Unit
P_1	Power, Primary side	kW
P_2	Power, Space Heating side	kW
P_3	Power, Domestic Hot Water	kW
t_{11}	Temperature, Primary Side Supply Connection	°C
t_{12}	Temperature, Primary Side Return connection	°C
t_{21}	Temperature, Space Heating Side Return Connection	°C
t_{22}	Temperature, Space Heating System Supply Connection	°C
t_{31}	Temperature, Cold Water Supply	°C
t_{32}	Temperature, Domestic hot Water Output from HIU	°C
q_1	Volume Flow, Primary side	L/s
q_2	Volume Flow, Space heating side	L/s
q_3	Volume flow, Domestic hot water	L/s
Δp_1	Primary Pressure drop across entire HIU unit	kPa
Δp_2	Pressure Drop, Space heating system across HIU	kPa
Δp_3	Pressure Drop, Domestic Hot Water across HIU	kPa
$VWART_{DHW}$	DHW Volume Weighted Return Temperature	°C
$VWART_{SH}$	Space Heating Volume Weighted Return Temperature	°C
$VWART_{KWH}$	Keep Warm Volume Weighted Return Temperature	°C
$VWART_{HEAT}$	Annual Volume Weighted Return Temperature for Heating Period	°C
$VWART_{NONHEAT}$	Annual Volume Weighed Return Temperature for Non-Heating	°C
$VWART_{HIU}$	Total Annual Volume Weighted Return Temperature	°C
DHW	Domestic Hot Water	—
HIU	Heat Interface Unit	—
SH	Space Heating	—
TMV	Thermostatic mixing Valve	—

3 TEST OBJECT

3.1 Appliance Details

3.1.1 Details of the HIU Greenstar HIU KE Plus with heat meter appliance are given in Table 3.1. Photograph of the installed appliance is given in Figure 8.1.

3.2 Design Pressures

3.2.1 The maximum design pressures of the Greenstar HIU KE Plus with heat meter appliance are given for the primary side and the secondary side for both Space Heating and DHW in Table 3.2.

3.3 Design temperatures

3.3.1 The maximum design temperatures of the Greenstar HIU KE Plus with heat meter appliance are given for the primary side and the secondary side for both Space Heating and DHW in Table 3.3

Table 3.1 – Appliance Details

Item	Description
Manufacturer	Worcester Bosch
Model	Greenstar HIU KE Plus with heat meter
Serial number	7733600134
Year of manufacture	2019
DHW priority	Yes

Table 3.2 – Appliance Design Pressures

Item	Value	Unit
Primary Side	10	Bar
Secondary Side space Heating	3	Bar
Secondary Side DHW	10	Bar

Table 3.3 – Appliance Design Temperatures

Item	Value	Unit
Primary Side	90	°C
Secondary Side space Heating	80	°C
Secondary Side DHW	60	°C

4 TEST METHOD

4.1 Installation of Appliance

4.1.1 The appliance was installed and commissioned (as received) and as defined in the product literature provided. Testing was carried out without further adjustment other than disabling the internal space heating pump and adjusting the setting of the SH and DHW set points through the user interface on the HIU controller to suit the conditions of the HIU test rig. The HIU rig schematic is given in Figure 4.1.

4.2 Test Regime

4.2.1 The testing described in this report was carried out in accordance with the BESA test regime¹. The Test Regime outlines a series of static and dynamic tests to determine the performance of a HIU's DHW and SH functions. The Regime outlines the test method including the reporting of the results, the performance requirements and the VWART calculations.

4.2.2 The setup of the BESA tests is reproduced in Table 4.1. The basis of reporting the performance of the HIU from the BESA Test Regime is reproduced in Table 4.2.

4.2.3 The Test Regime specifies the testing of two different test temperature packages. The first is the high temperature package, with a district primary supply of 70 °C and the second is the 'low temperature' package, with a district primary supply temperature of 60 °C.

4.2.4 As the Worcester Bosch, Greenstar HIU KE Plus with heat meter is suitable for both high and low temperature operation, both test packages were carried out and results recorded within this report.

4.3 Measurement & Uncertainties

4.3.1 All measurements and uncertainties adhere to the requirements stipulated in the BESA Test Regime. All measurements were sampled at a rate of 1 Hz for all tests.

4.3.2 The BESA uncertainties of measurement requirements are as follows: Differential Pressure, ± 1 kPa; Temperature, ± 0.1 °C; Volume Flow, ± 1.5 %. Note: the time constant for the temperature sensors is less than 1.5 s.

4.3.3 EIL's reported uncertainty is based on a standard uncertainty by a coverage factor $K=2$, providing a level of confidence of approximately 95%. The uncertainty evaluation has been carried out in accordance with UKAS requirements. The EIL equipment list and uncertainties are given in Table 8.3, Appendix B.

¹ UK HIU Test Regime Technical Specification, Rev-009 requirements, issued by the Building Engineering Services Association (BESA)

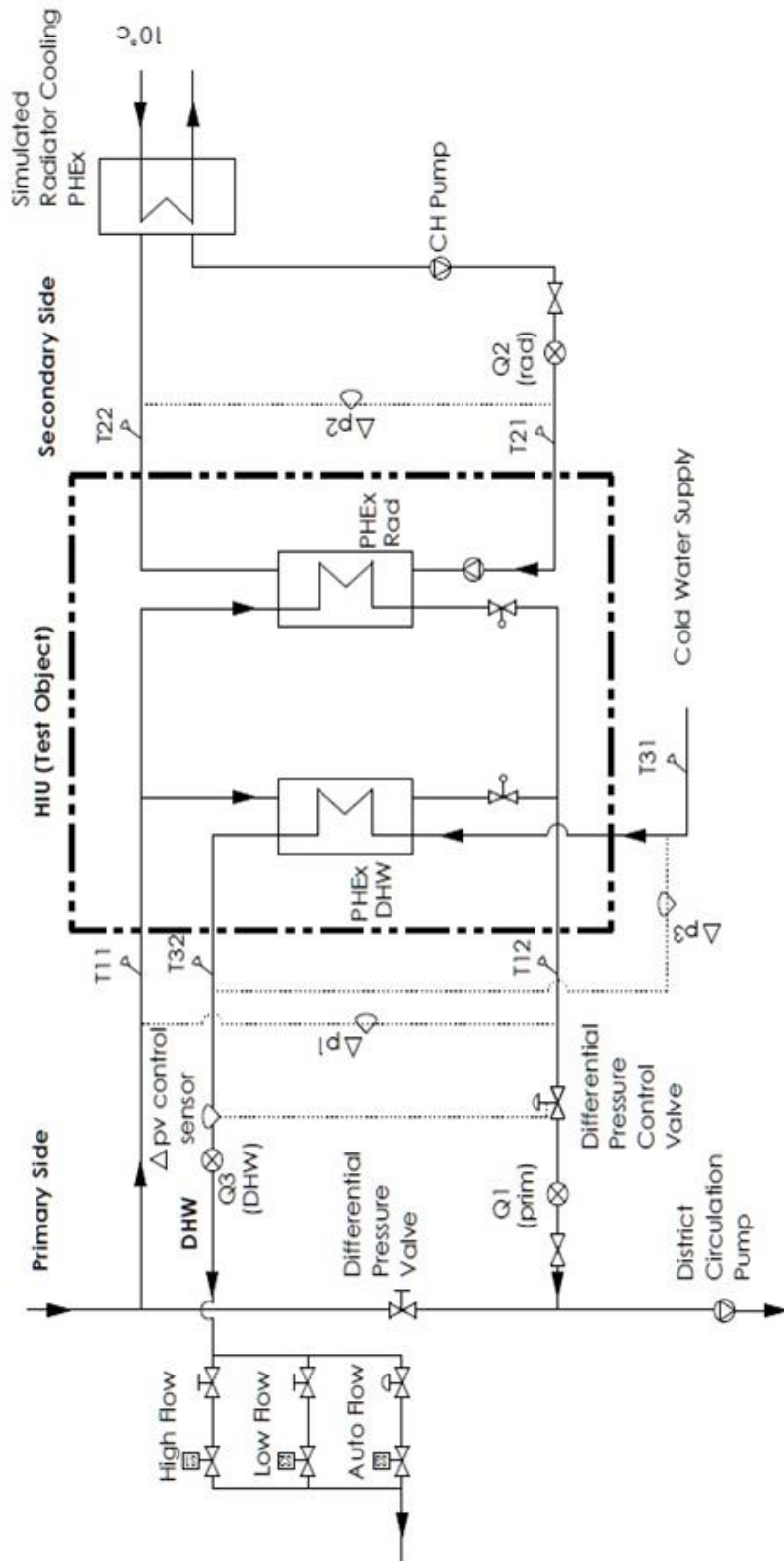

Figure 4.1 – EIL’s HIU Test Rig schematic

Table 4.1 – Setup of tests (extracted from BESA Test Regime)

No	Test	static pressure on return	dP across HIU	Primary flow temp	DHW setpoint	DHW flow rate	DHW power	SH output	SH flow temp	SH return temp
		bar	bar	°C	°C	l/s	kW	kW	°C	°C
			dP_1	t_{11}	t_{32}	q_3	P_3	P_2	t_{22}	t_{21}
Static tests										
0a	Static pressure test (same static pressure on both flow and return connections)	1.43 times rated value	1.43 times rated value	n/a	n/a	n/a	n/a	n/a	n/a	n/a
1a	Space Heating 1 kW (DH 70 °C flow)	2.5	0.5	70	55	0	0	1	60	40
1b	Space Heating 2 kW (DH 70 °C flow)	2.5	0.5	70	55	0	0	2	60	40
1c	Space Heating 4 kW (DH 70 °C flow)	2.5	0.5	70	55	0	0	4	60	40
1d	Space Heating 1 kW (DH 60 °C flow)	2.5	0.5	60	50	0	0	1	45	35
1e	Space Heating 2 kW (DH 60 °C flow)	2.5	0.5	60	50	0	0	2	45	35
1f	Space Heating 4 kW (DH 60 °C flow)	2.5	0.5	60	50	0	0	2	45	35
Dynamic tests										
2a	DHW only (DH 70 °C flow)	2.5	0.5	70	55	DHW test profile	DHW test profile	0	n/a	n/a
2b	DHW only (DH 60 °C flow)	2.5	0.5	60	50	DHW test profile	DHW test profile	0	n/a	n/a
3a	Low flow DHW (DH 70 °C flow)	2.5	0.5	70	55	0.02	Record value	0	n/a	n/a
3b	Low flow DHW (DH 60 °C flow)	2.5	0.5	60	50	0.02	Record value	0	n/a	n/a
4a	Keep-warm (DH 70 °C flow)	2.5	0.5	70	55	0	0	0	n/a	n/a
4b	Keep-warm (DH 60 °C flow)	2.5	0.5	60	50	0	0	0	n/a	n/a
5a	DHW response time (DH 70 °C flow)	2.5	0.5	70	55	0.13	Record value	0	n/a	n/a
5b	DHW response time (DH 60 °C flow)	2.5	0.5	60	50	0.13	Record value	0	n/a	n/a

Table 4.2 – Test Reporting, adapted from BESA Test Regime

Test	Description	Reporting
Static Tests		
0	Pressure Tests.	Pass/Fail as to whether HIU manages pressure test without leaks or damage.
1a	Space heating 1 kW, 60/40 °C secondary.	t_{11} – Primary flow temperature. t_{12} – Primary return temperature. Plot of key metrics over duration of test. Note: Outputs used as input data to ‘High Temperature’ Space Heating Volume Weighted Average Return Temperature calculation.
1b	Space heating 2 kW, 60/40 °C secondary.	
1c	Space heating 4 kW, 60/40 °C secondary.	
1d	Space heating 1 kW, 45/35 °C secondary.	
1e	Space heating 2 kW, 45/35 °C secondary.	t_{11} – Primary flow temperature. t_{12} – Primary return temperature. Plot of key metrics over duration of test. Note: Outputs used as input data to ‘Low Temperature’ Space Heating Volume Weighted Average Return Temperature calculation.
1f	Space heating 4 kW, 45/35 °C secondary.	
Dynamic Tests		
2a	DHW only, DH 70 °C flow; 55 °C DHW.	Pass/Fail on DHW (at t_{32}) exceeding 65.0 °C (to 1 decimal point) for more than 10 consecutive seconds. ‘State the maximum and minimum DHW temperatures over the period of the test when there is a DHW flow. Assessment of scaling risk as per the criteria detailed in 2.26. Note: Outputs used as input data to ‘High Temperature’ Space Heating Volume Weighted Average Return Temperature calculation. Plot t_{32} , t_{31} , q_3 , t_{12} , q_1
2b	DHW only, DH 60 °C flow; 50 °C DHW.	State the maximum and minimum DHW temperatures over the period of the test when there is a DHW flow. Plot q_1 , q_3 , dp_1 , dp_3 Note: Outputs used as input data to ‘Low Temperature’ Domestic Hot Water Volume Weighted Average Return Temperature calculation.
3a	Low flow DHW, DH 70 °C flow; 55 °C DHW.	Pass/Fail on DHW (at t_{32}) exceeding 65.0 °C (1 decimal place) for more than 10 consecutive seconds. Comment on ability to deliver DHW at low flow based on DHW temperature reaching at least 45.0 °C (1 decimal place) at the end of the 180 second period of low flow DHW. Comment on the ability to deliver stable DHW flow temperature (at t_{32}), defined as ability to maintain 55.0 +/- 3.0 °C (1 decimal place) during the last 60 seconds of the test. Maximum temperature achieved and +/- °C variance around 55.0 °C (1 decimal place) to be stated. Assessment of scaling risk as per criteria detailed in 2.26. Plot of key metrics for 60 seconds of 0.13 l/s flow and the subsequent 180 seconds of 0.02 l/s DHW flow.
3b	Low flow DHW, DH 60 °C flow; 50 °C DHW.	Comment on the ability to deliver DHW at low flow rate based on DHW temperature reaching at least 45 °C (1 decimal place) at the end of the 180 second period of low flow DHW. Comment on the ability to deliver stable DHW flow temperature (at t_{32}), defined as ability to maintain 50.0 +/- 3 °C (1 decimal place) to be stated. Plot of key metrics for 60 seconds of 0.13 l/s flow and the subsequent 180 seconds of 0.02 l/s DHW flow. Maximum temperature achieved and +/- °C variance around 50.0 °C (1 decimal place) to be stated.
4a	Keep-warm, DH 70 °C flow; 55 °C DHW.	Assessment of whether valid keep-warm operation, based on 5a response time criteria: Pass/Fail. Plot temperature t_{10}

		<p>Assessment of scaling risk, based on duration of temperatures in excess of 55.0 °C (1 decimal place).</p> <p>Comment on HIU keep-warm controls options.</p> <p>Plot of key metrics over duration of test.</p> <p>State average heat load for the duration of the test.</p> <p>State the average primary flow rate for the duration of the test.</p> <p>Note: Outputs used as input data to 'High Temperature' Keep-warm Volume Weighted Average Return Temperature calculation.</p>
4b	Keep-warm, DH 60 °C flow; 50 °C DHW.	<p>Assessment of whether valid keep-warm operation, based on 5a response time criteria: Pass/Fail.</p> <p>Observation on the operation of the HIU during keep-warm.</p> <p>Assessment of scaling risk based on extent and duration of temperatures in excess of 55.0 °C (1 decimal place).</p> <p>Comment on HIU keep-warm controls options.</p> <p>Plot of key metrics over duration of test.</p> <p>State average heat load for the duration of the test.</p> <p>State the average primary flowrate for the duration of the test.</p> <p>Note: Outputs used as input data to 'Low Temperature' Keep-warm Volume Weighted Average Return Temperature calculation.</p>
5a	DHW response time, DH 70 °C flow; 55 °C DHW.	<p>Pass/Fail on DHW (at t_{32}) exceeding 65.0 °C (1 decimal place) for more than 10 consecutive seconds.</p> <p>State time to achieve 45.0 °C (1 decimal place) and not subsequently drop below 42.0 °C (1 decimal place).</p> <p>Plot $t_{32}, t_{31}, t_{12}, q_1$</p>
5b	DHW response time, DH 60 °C flow; 50 °C DHW.	<p>State time to achieve a DHW temperature 45.0 °C (1 decimal place) and not subsequently drop below 42.0 °C (1 decimal place).</p> <p>Comment on stability of DHW temperature.</p> <p>Plot $t_{32}, t_{31}, t_{12}, q_1$ over duration of test.</p>

5 TEST RESULTS

5.1 Test 0 –Pressure Test

5.1.1 The appliance has passed the requirements of the static pressure test, Test 0 of the BESA Test Regime as:

5.1.2 There was No damage observed during the static pressure test, with the primary flow pressurised to 14.3 bar (1.43 times the rated value), and;

5.1.3 There were No leaks observed during the static pressure test, with the primary flow pressurised to 14.3 bar (1.43 times the rated value).

5.2 Test 1a to 1f – Space Heating 1-4 kW at 70 and 60 °C

5.2.1 The plot of the key metrics of Tests 1a-1f for the space heating 1 - 4 kW at both 70 and 60 °C are displayed in Figure 7.1 to Figure 7.6 respectively. See Table 5.1 for summarised test results including the average primary return temperature, t_{12} .

Table 5.1 - Test Results for Space Heating Tests 1a to 1f

Test	Description	Primary					Secondary				
		t_{11} °C	t_{12} °C	q_1 l/s	Δp_1 kPa	P_1 W	t_{21} °C	t_{22} °C	q_2 l/s	Δp_2 kPa	P_2 W
1a	- 1 kW Space Heating (DH 70 °C flow)	69.9	42.0	0.010	58.9	1198	40.1	60.0	0.012	1.4	995
1b	- 2 kW Space Heating (DH 70 °C flow)	70.3	43.3	0.020	55.9	2264	40.0	60.7	0.024	1.2	2046
1c	- 4 kW Space Heating (DH 70 °C flow)	69.9	45.1	0.041	50.4	4205	40.0	60.1	0.048	1.1	4041
1d	- Space Heating 1 kW (DH 60 °C flow)	60.3	35.6	0.011	53.9	1120	34.8	46.2	0.023	1.4	1076
1e	- Space Heating 2 kW (DH 60 °C flow)	59.7	36.4	0.020	51.7	1975	35.0	46.5	0.041	3.1	1968
1f	- Space Heating 4 kW (DH 60 °C flow)	60.2	36.7	0.040	49.7	3960	35.1	45.3	0.096	5.8	4066

5.3 Test 2a – DHW only at 70 °C

- 5.3.1 The appliance has passed the requirements of the DHW only at 70 °C, Test 2a of the BESA Test Regime as:
- 5.3.2 The domestic hot water output temperature, t_{32} did not exceed 65 °C for more than 10 seconds.
- 5.3.3 The maximum and minimum temperatures of t_{32} were 58.4°C and 37.4°C respectively.
- 5.3.4 The plot of the key metrics of the duration of Test 2a is displayed in Figure 7.7, Appendix.

5.4 Test 2b – DHW only at 60 °C

- 5.4.1 The maximum and minimum temperatures of t_{32} were 52.2°C and 36.1°C respectively.
- 5.4.2 The plot of the key metrics of the duration of Test 2b is displayed in Figure 7.8, Appendix.

5.5 Test 3c – Low Flow DHW at 70 °C

- 5.5.1 The HIU met the requirements of test 3a of not exceeding 65°C for more than 10 seconds in accordance with the test method (maximum temperature reached was 59.06°C) The HIU did not provide stable flow temperatures of 55°C +/- 3°C for >60 seconds under the stated conditions.
- 5.5.2 As the appliance failed to provide stable flow temperatures during test 3a the appliance was retested as test 3c at the manufactures low flow rate. The appliance has passed the requirements of the Low Flow at 70 °C, Test 3c of the BESA Test Regime as:
- 5.5.3 The manufacturers declared low flow rate was 2.4 l/m which is higher than the BESA test rate of 1.2 l/m
- 5.5.4 The domestic hot water output temperature, t_{32} did not exceed 65 °C for more than 10 seconds and;
- 5.5.5 The appliance did maintain the DHW output temperature, t_{32} at 55 ± 3 °C during the last 60 seconds of the test.
- 5.5.6 The maximum and minimum temperatures of t_{32} were 59.3°C and 49.32°C respectively.
- 5.5.7 The plot of the key metrics of the duration of Test 3c is displayed in Figure 7.9, Appendix.

5.6 Test 3d – Low Flow DHW at 60 °C

- 5.6.1 The HIU met the requirements of test 3b of not exceeding 65°C for more than 10 seconds in accordance with the test method (maximum temperature reached was 52.81°C) The HIU did not provide stable flow temperatures of 55°C +/- 3°C for >60 seconds under the stated conditions.

- 5.6.2 As the appliance failed to provide stable flow temperatures during test 3b the appliance was retested as test 3d at the manufactures low flow rate. The appliance has passed the requirements of the Low Flow at 60 °C, Test 3d of the BESA Test Regime as:
- 5.6.3 The manufacturers declared low flow rate was 2.4 l/m which is higher than the BESA test rate of 1.2 l/m
- 5.6.4 The appliance did maintain the DHW output temperature, t_{32} at 50 ± 3 °C during the last 60 seconds of the test.
- 5.6.5 The maximum and minimum temperatures of t_{32} were 54.22°C and 46.47°C respectively.
- 5.6.6 The plot of the key metrics of the duration of Test 3d is displayed in Figure 7.10, Appendix.

5.7 Test 4a – Keep-warm at 70 °C

- 5.7.1 The appliance has passed the requirements of the Keep-warm at 70 °C, Test 4a of the BESA Test Regime as:
- 5.7.2 This is a valid keep warm operation based on 5a response time criteria, see 5.9.3.
- 5.7.3 The appliance is not performing keep-warm cycling as the primary flow temperature, t_{11} does not vary by more than ± 3 °C during the final 3 hours of the test.
- 5.7.4 The appliance is not performing keep-warm function as no cycling was observed.
- 5.7.5 The DHW output temperature, t_{32} was in excess of 55 °C for a total of 0 seconds throughout the duration of the test.
- 5.7.6 The average heat load on the primary side P_1 is 40.9 W.
- 5.7.7 The average primary flow q_1 over the 8 hour test was 5.892 l/hr.
- 5.7.8 The Keep-warm control was set to 5.2 on the by-pass.
- 5.7.9 The plot of the key metrics of the duration of Test 4a is displayed in Figure 7.11, Appendix.

5.8 Test 4b – Keep-warm at 60 °C

- 5.8.1 The appliance has passed the requirements of the Keep-warm at 60 °C, Test 4b of the BESA Test Regime as:
- 5.8.2 This is a valid keep warm operation based on 5b response time criteria, see 5.10.1.
- 5.8.3 The appliance is not performing keep-warm cycling as the primary flow temperature, t_{11} does not vary by more than ± 3 °C during the final 3 hours of the test.
- 5.8.4 The appliance is not performing a keep-warm function as no cycling was observed.
- 5.8.5 The DHW output temperature, t_{32} was in excess of 55 °C for a total of 0 seconds throughout the duration of the test.
- 5.8.6 The average heat load on the primary side P_1 is 48.9 W.

5.8.7 The average primary flow q_1 over the 8 hour test was 12.507 l/hr.

5.8.8 The plot of the key metrics of the duration of Test 4b is displayed in Figure 7.12, Appendix.

5.9 Test 5a – DHW Response Time at 70 °C

5.9.1 The appliance has passed the requirements of DHW Response Time at 70°C, Test 5a of the BESA Test Regime as:

5.9.2 The domestic hot water output temperature, t_{32} did not exceed 65 °C for more than 10 seconds.

5.9.3 The DHW response time for t_{32} to reach 45 °C (and not subsequently drop below 42 °C) was 15 seconds; therefore this is a valid keep warm.

5.9.4 The plot of the key metrics of the duration of Test 5a is displayed in Figure 7.13, Appendix.

5.10 Test 5b – DHW Response Time at 60 °C

5.10.1 The DHW response time for t_{32} to reach 45 °C (and not subsequently drop below 42 °C) was 15 seconds; therefore this is a valid keep warm.

5.10.2 The plot of the key metrics of the duration of Test 5b is displayed in Figure 7.14, Appendix.

5.11 Overall Scaling Risk Assessment

5.11.1 If any of the below factors occur then the risk of scaling of the DHW plate in hard water areas increases.

Table 5.2 - Overall Scaling Risk Assessment

<i>HIU has a TMV or TRV on the output of the DHW plate heat exchanger.</i>	No	
Test Designation	2a	3a
<i>t₃₂ above 60°C for more than 5 seconds</i>	No	No
<i>t₁₂ exceeds 55°C at any point of the test</i>	No	No
Test Designation	4a	4b
<i>t₁₂ exceeds 50°C at any time</i>	Yes	Yes

5.12 Test Summary



Low Temperature VVART Calculation for Greenstar HIU KE+ with heat meter

Primary flow temperature: 60°C; DHW set point: 50°C; Space heating temperatures: 45°C/35°C

Test carried out by Enertek International for HIGH Temperature BESA Tests

Manufacturer: Worcester Bosch; Model: Greenstar HIU E+ with heat meter; Serial number: 7733600134 ;

VVART calculation prepared by Ian Williamson of Enertek International on 31 October 2019

	VVART(°C)	Volume (m3)
DHW	21	31.6
Standby	50	100.3
Space Heating	36	53.1

Period	VVART(°C)	% Time
No Heating	43	93%
Heating	37	7%
Overall	42	

	DHW Draw test results		Post DHW Draw (60 seconds)	
	Power (W)	Primary flow (l/s)	VVART (°C)	VVART (°C)
Low	9246	0.056	20	18
Medium	16421	0.102	21	20
High	21394	0.134	22	21

	DHW Draw Volumes pa		Post DHW Draw Volumes pa	
	kWh pa	Hours	Average duration (secs)	Volume pa (m ³)
Low	729	75.00	10000	30
Medium	297	18.00	660	75
High	444	21.00	300	145

Standby	Standby test results	
	Primary flow (Ls ⁻¹)	VVART (°C)
	0.003000	50

Standby	Standby Volumes pa	
	Hours	Volume pa (m ³)
	8,086	101.10

	Space Heating test results	
	Power (W)	Primary flow (m ³ /hr)
1kWp	1076	0.011
2kWp	1968	0.020
4kWp	4066	0.040

	Space Heating Volumes pa	
	Hours	Volume pa (m ³)
1kWp	98	3.60
2kWp	787	29.40
4kWp	565	20.20

Table 7.1 and Table 7.2, Appendix for the summary of key metrics of all the tests described in this report.

5.13 VWART Calculations

5.13.1 The Volume Weighted Average Return Temperatures (VWART) have been calculated as stipulated in the BESA UK HIU Test Regime document. The calculated VWART values for both the high temperature and low temperature tests described in this report are given below in Table 5.3 and Table 5.4 respectively.

Table 5.3 – High Temperature VWART Calculations

Symbol	Description	Value
SH _{PROP}	Annual Heating Period percentage	7.0
NSH _{PROP}	Annual Non-Heating Period percentage	93.0
VWART _{SH}	Space Heating Volume Weighted Return Temperature	44
VWART _{DHW}	DHW Volume Weighted Return Temperature	20
VWART _{KWM}	Keep Warm Volume Weighted return Temperature	49
VWART _{HEAT}	Annual Volume Weighted Return Temperature For Heating Period	44
VWART _{NONHEAT}	Annual Volume Weighted Return Temperature For Non Heating	39
VWART _{HIU}	Total Annual Volume Weighted Return Temperature	40

Table 5.4 – Low Temperature VWART Calculations

Symbol	Description	Value
SH _{PROP}	Annual Heating Period percentage	7.2
NSH _{PROP}	Annual Non-Heating Period percentage	92.8
VWART _{SH}	Space Heating Volume Weighted Return Temperature	36
VWART _{DHW}	DHW Volume Weighted Return Temperature	21
VWART _{KWM}	Keep Warm Volume Weighted return Temperature	50
VWART _{HEAT}	Annual Volume Weighted Return Temperature For Heating Period	37
VWART _{NONHEAT}	Annual Volume Weighted Return Temperature For Non Heating	43
VWART _{HIU}	Total Annual Volume Weighted Return Temperature	43

6 CONCLUSIONS

- 6.1.1 The appliance has satisfied the performance requirements of the BESA HIU Test Regime.
- 6.1.2 The manufacturers declared low flow rate was 2.4 l/m which is higher than the BESA test rate of 1.2 l/m.

All conclusions, opinions and interpretations indicated in this report are outside the scope of Enertek's UKAS accreditation.

7 APPENDIX A

7.1 Key Metric Plots

7.1.1 The graphical plots of the key metrics of the tests described in this report are given in this section.

GRAPHICAL PLOTS START ON NEXT PAGE

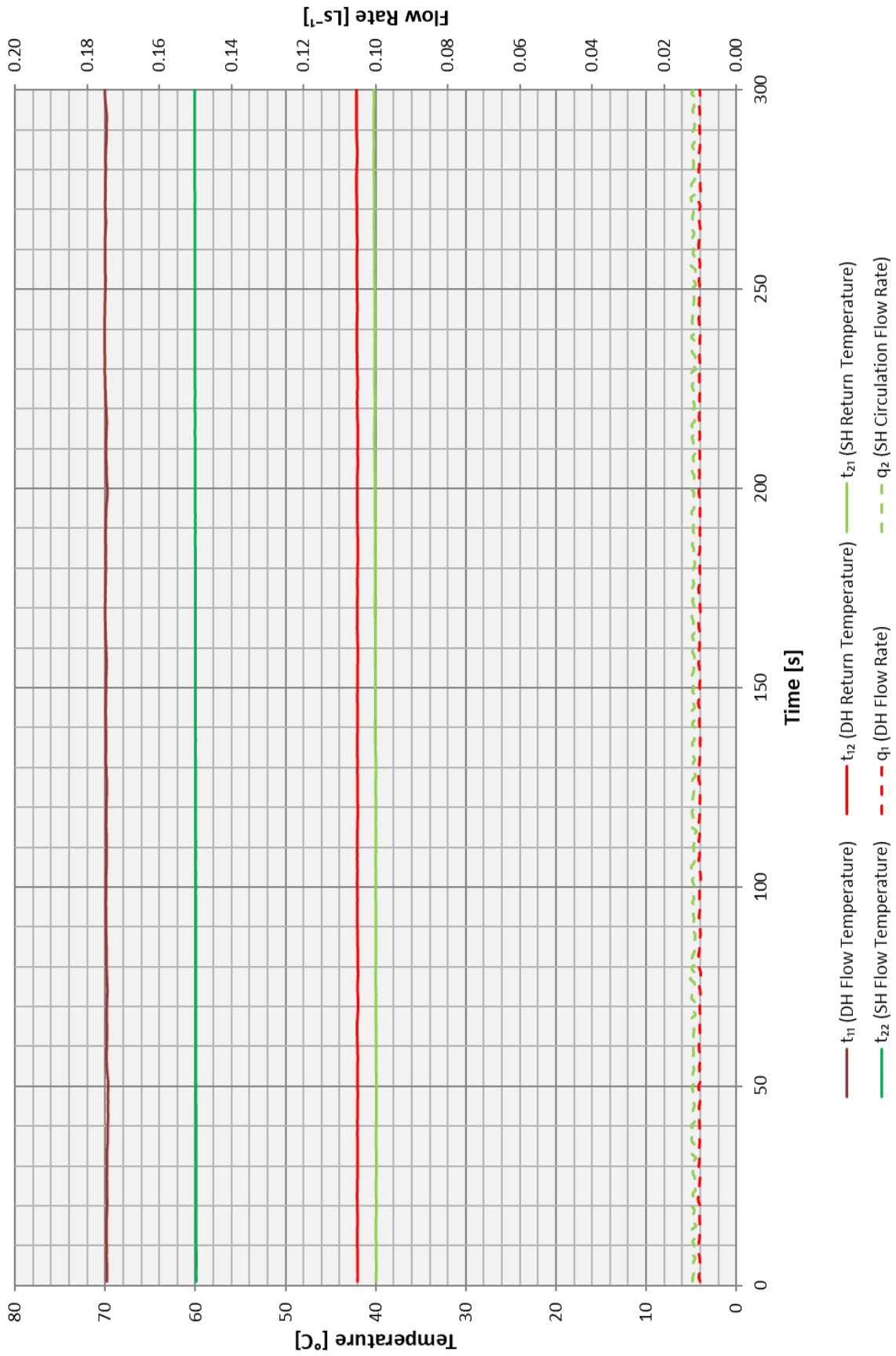

Figure 7.1 - Test 1a – Space Heating 1 kW at 70 °C

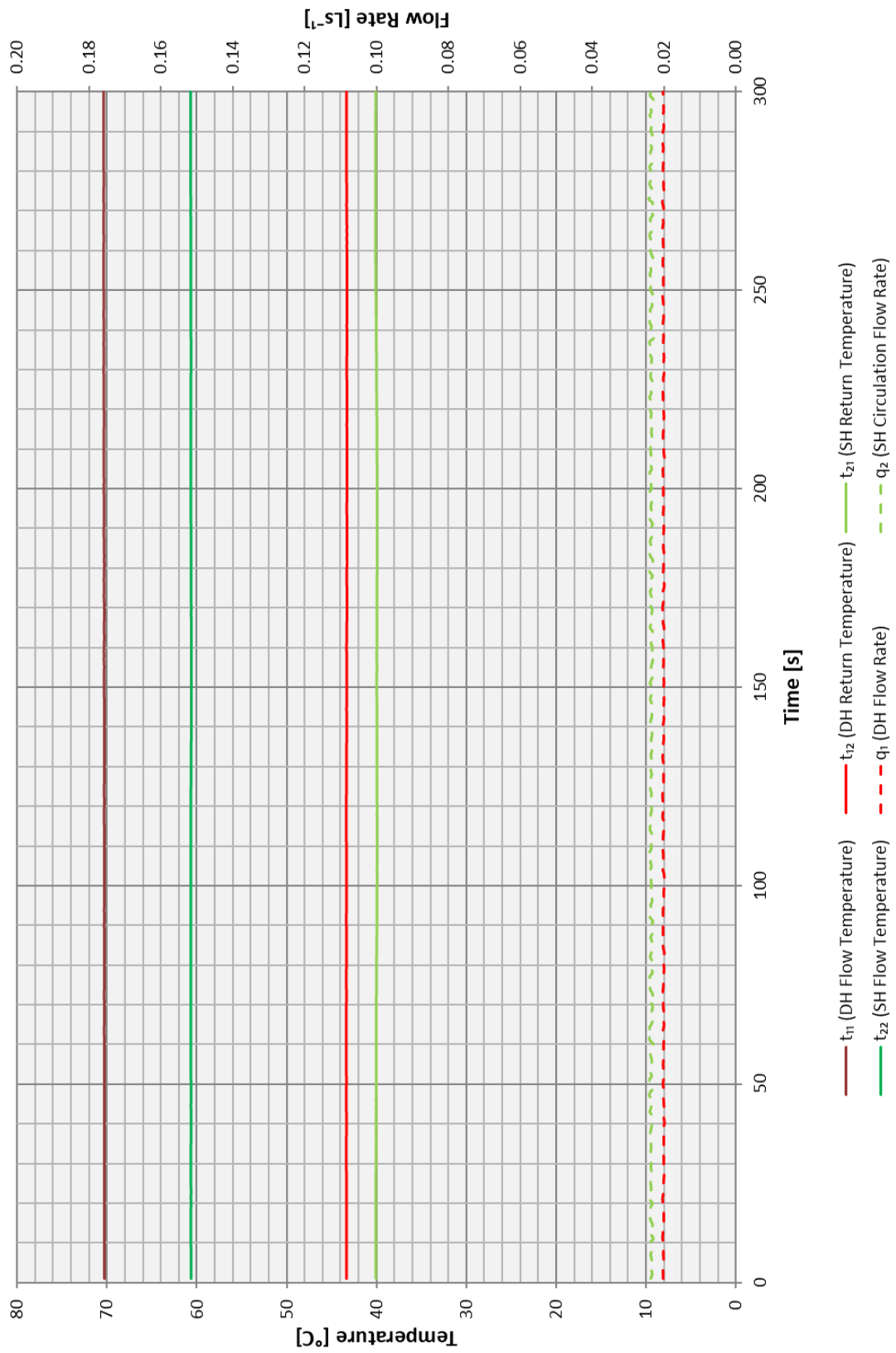

Figure 7.2 - Test 1b – Space Heating 2 kW at 70 °C

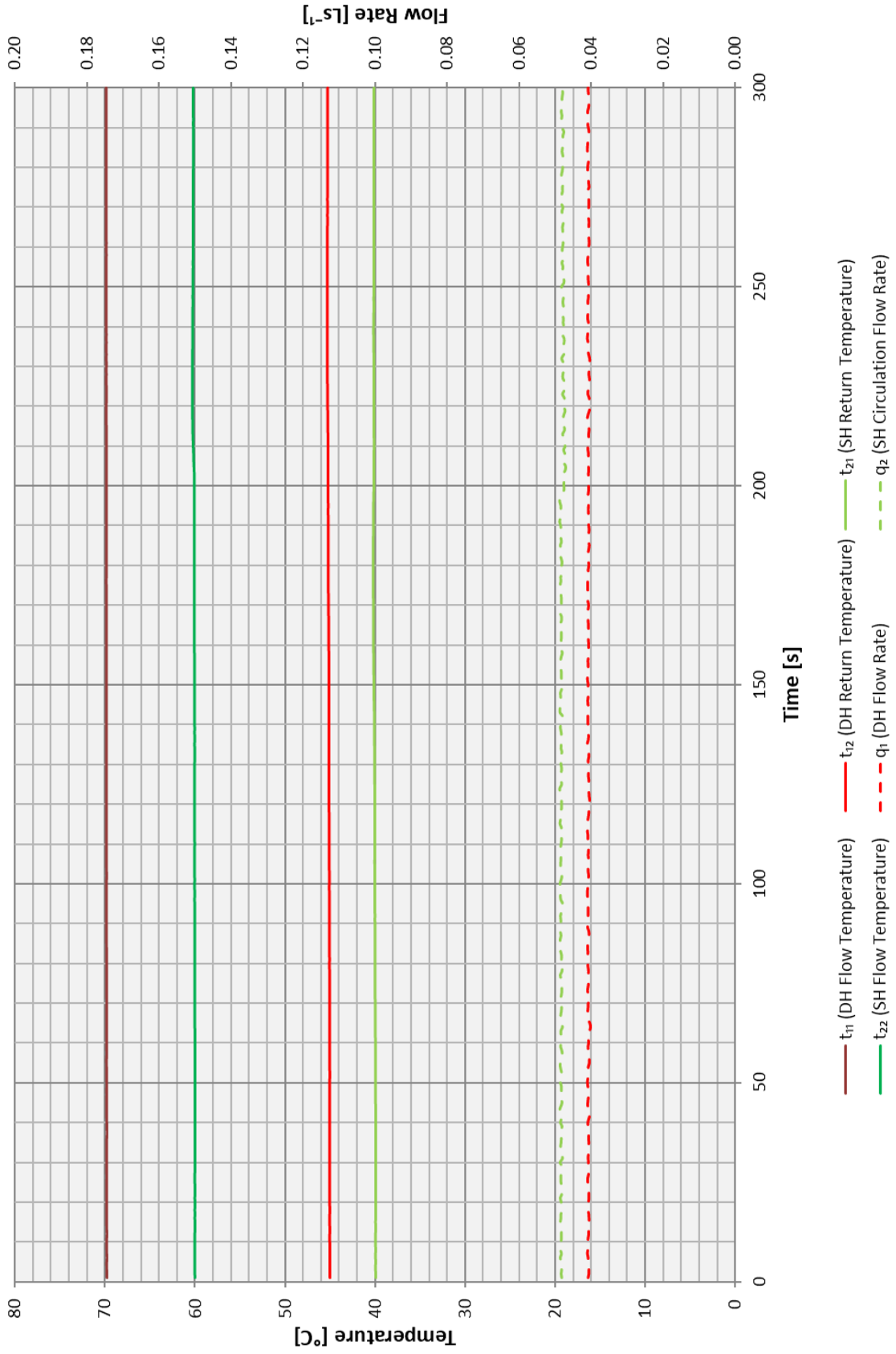

Figure 7.3 - Test 1c – Space Heating 4 kW at 70 °C

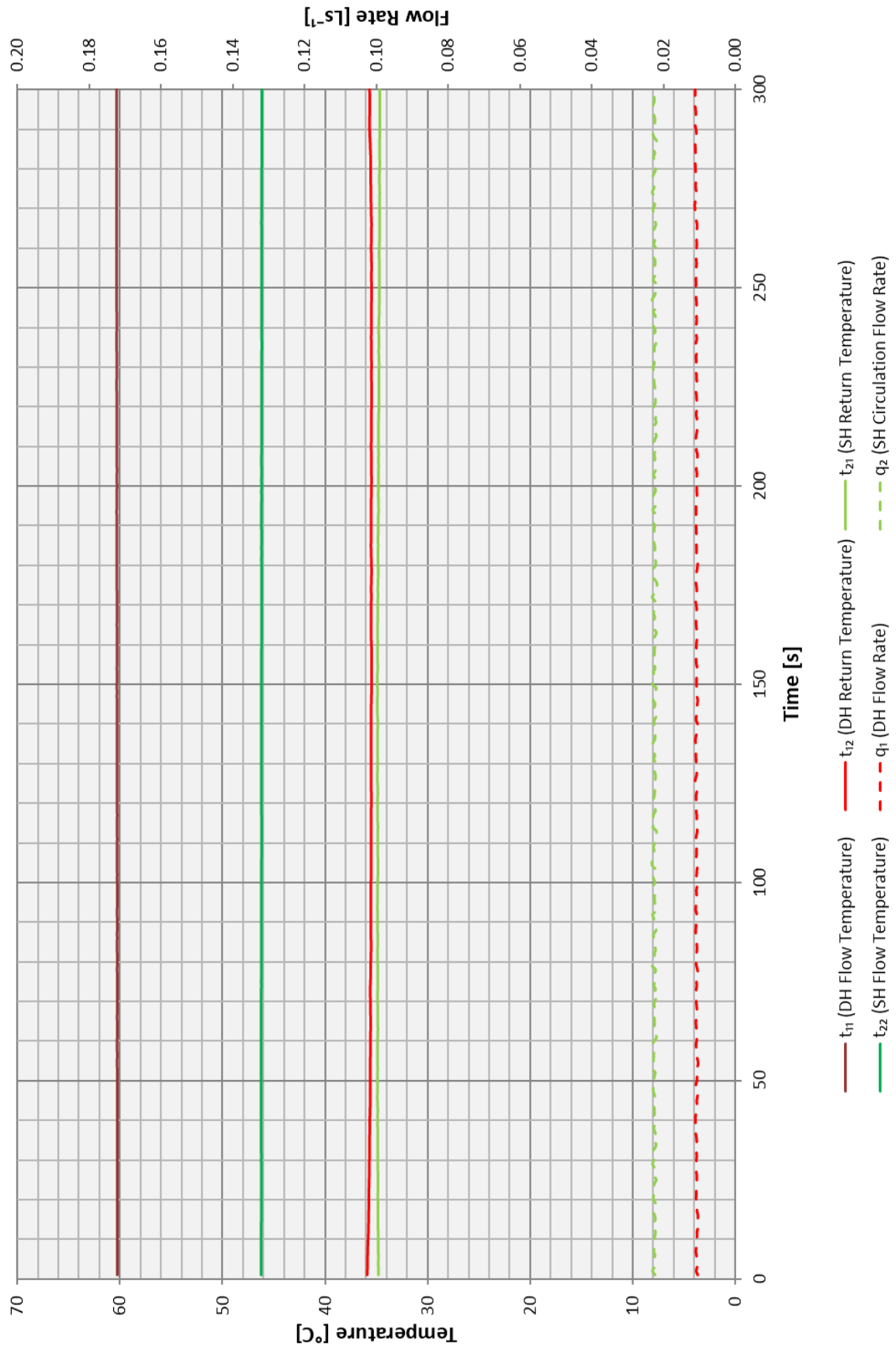

Figure 7.4 - Test 1d – Space Heating 1 kW at 60 °C

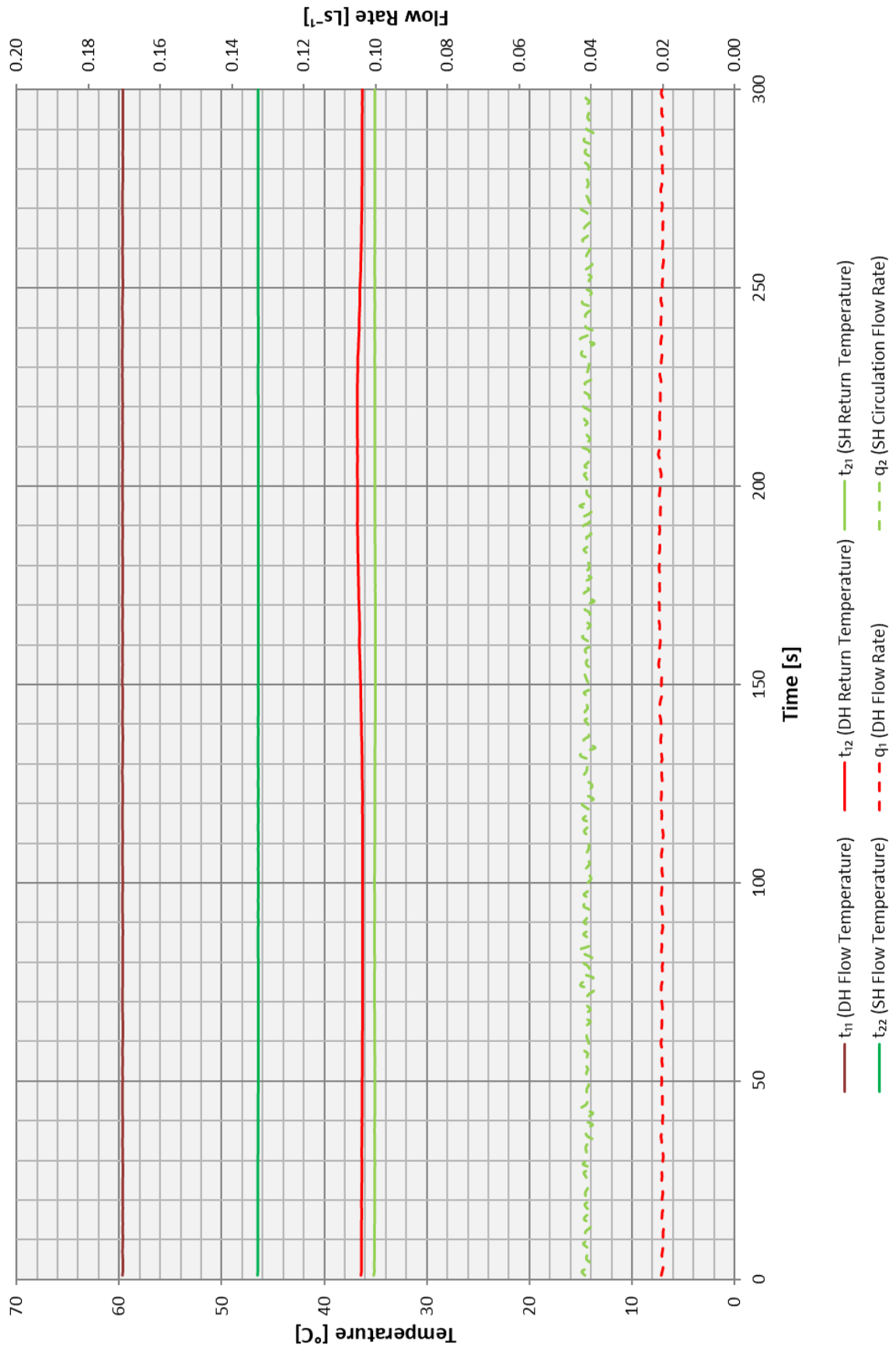

Figure 7.5 - Test 1e – Space Heating 2 kW at 60 °C

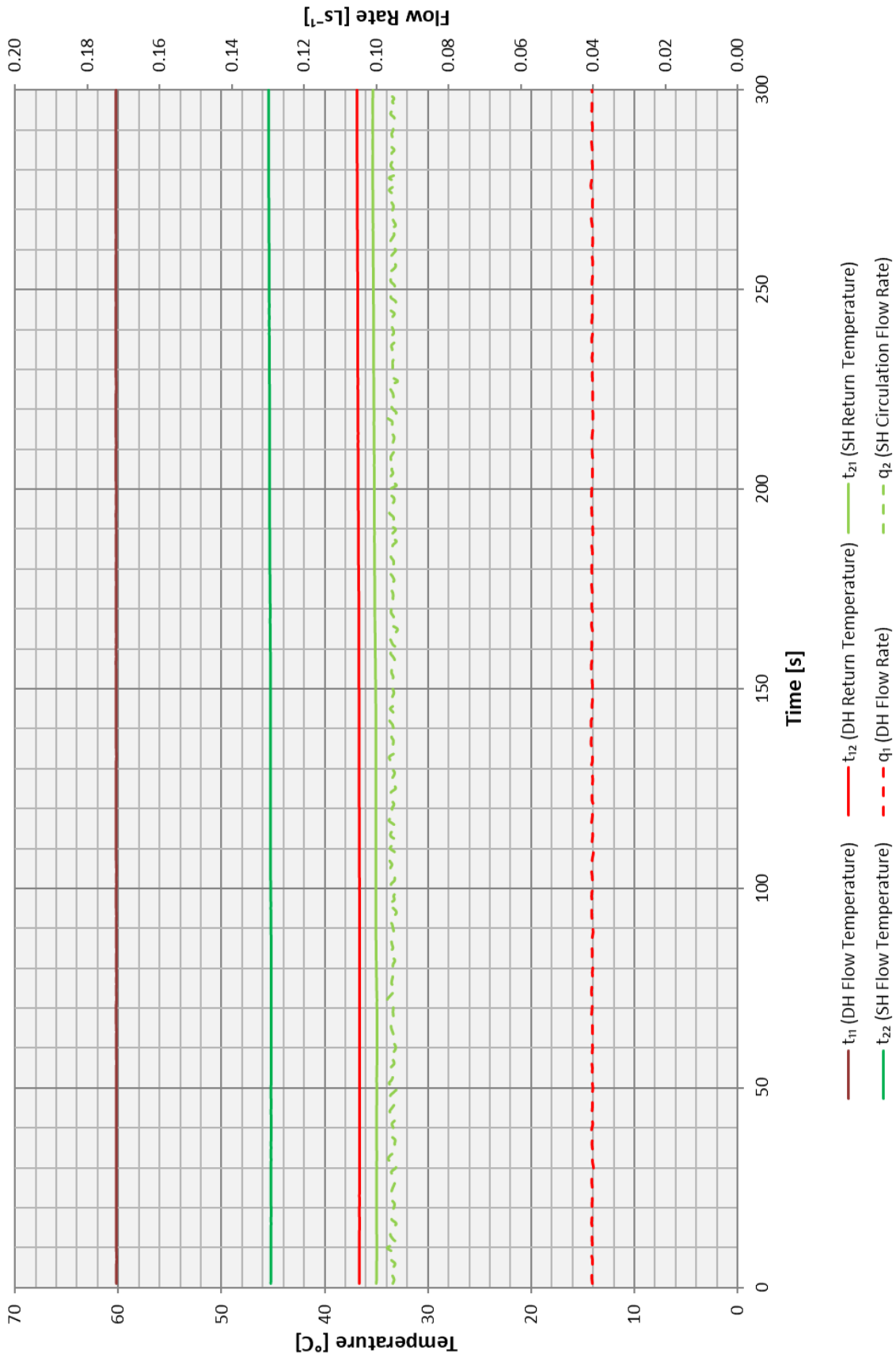

Figure 7.6 - Test 1f – Space Heating 4 kW at 60 °C

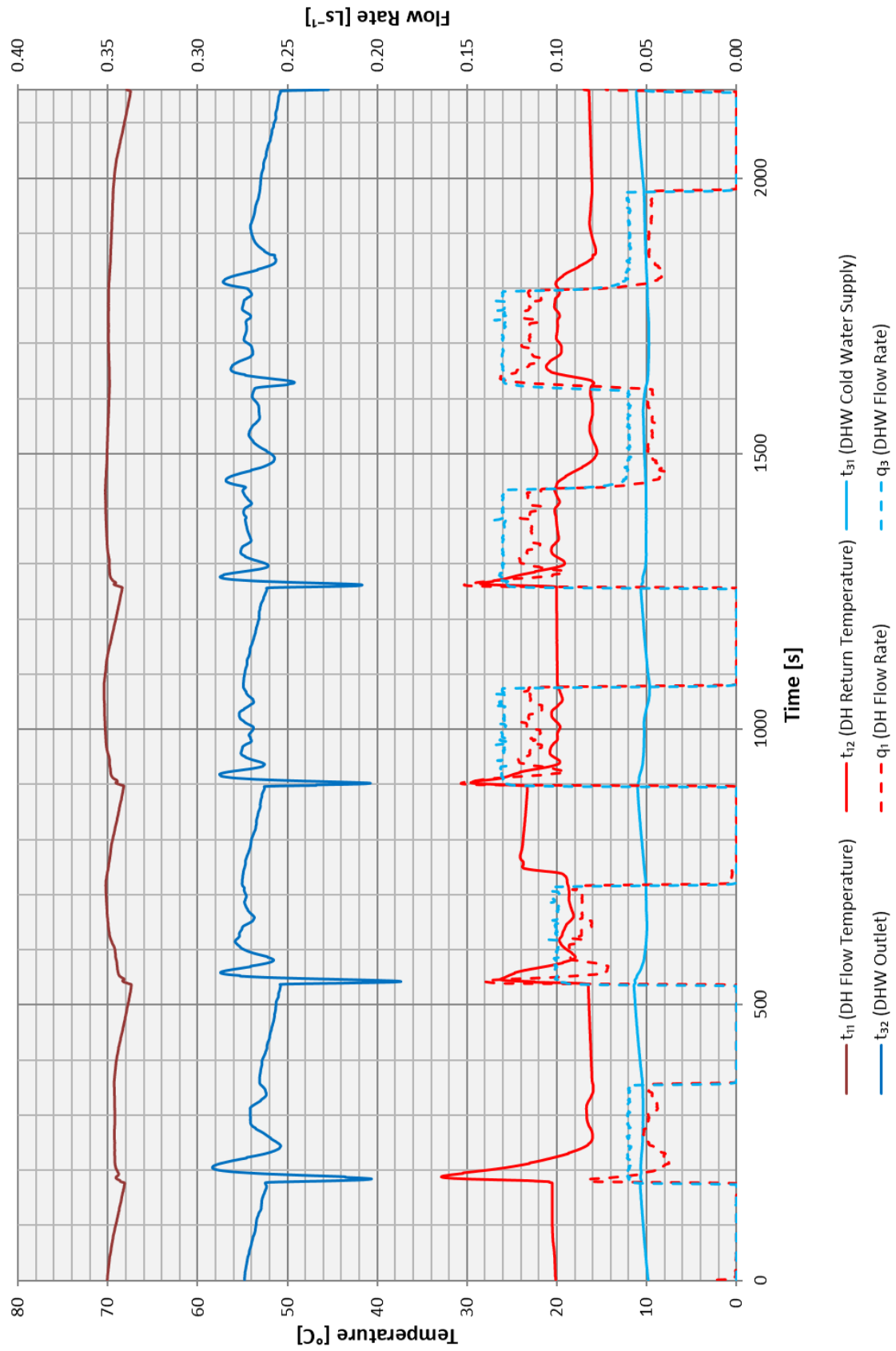

Figure 7.7 - Test 2a – DHW only at 70 °C

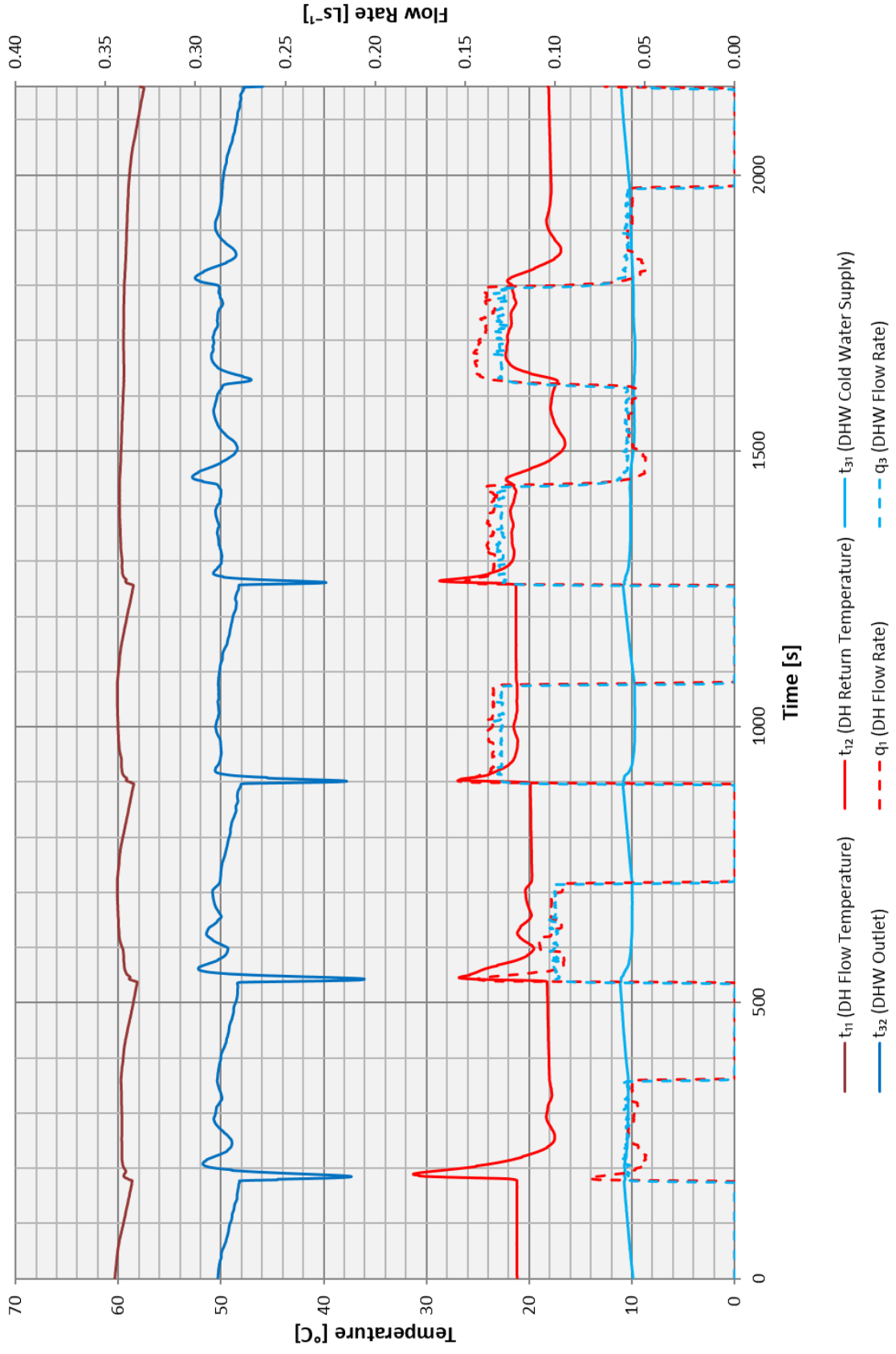

Figure 7.8 - Test 2b – DHW only at 60 °C

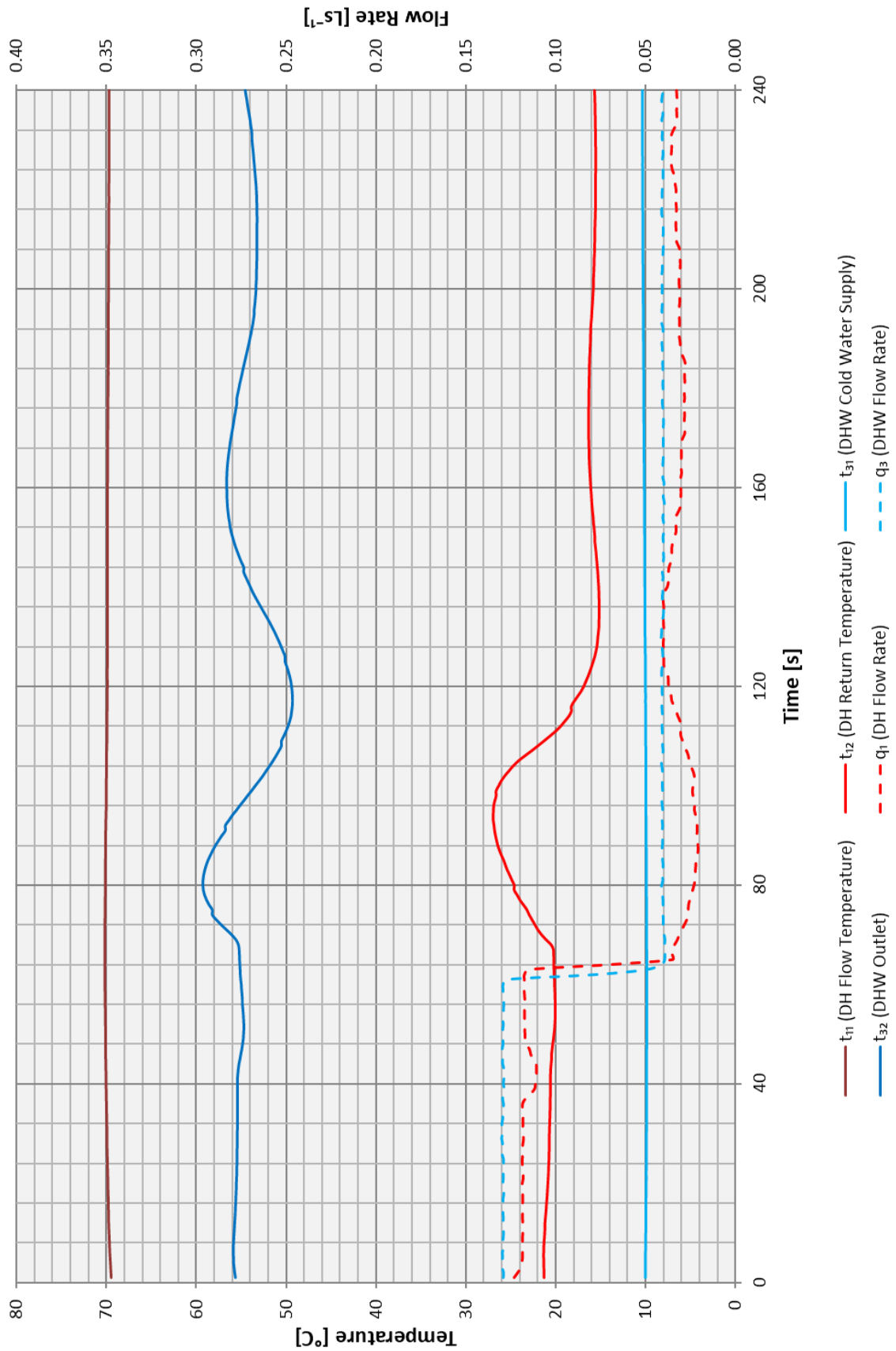

Figure 7.9 - Test 3c – Low Flow DHW at 70 °C

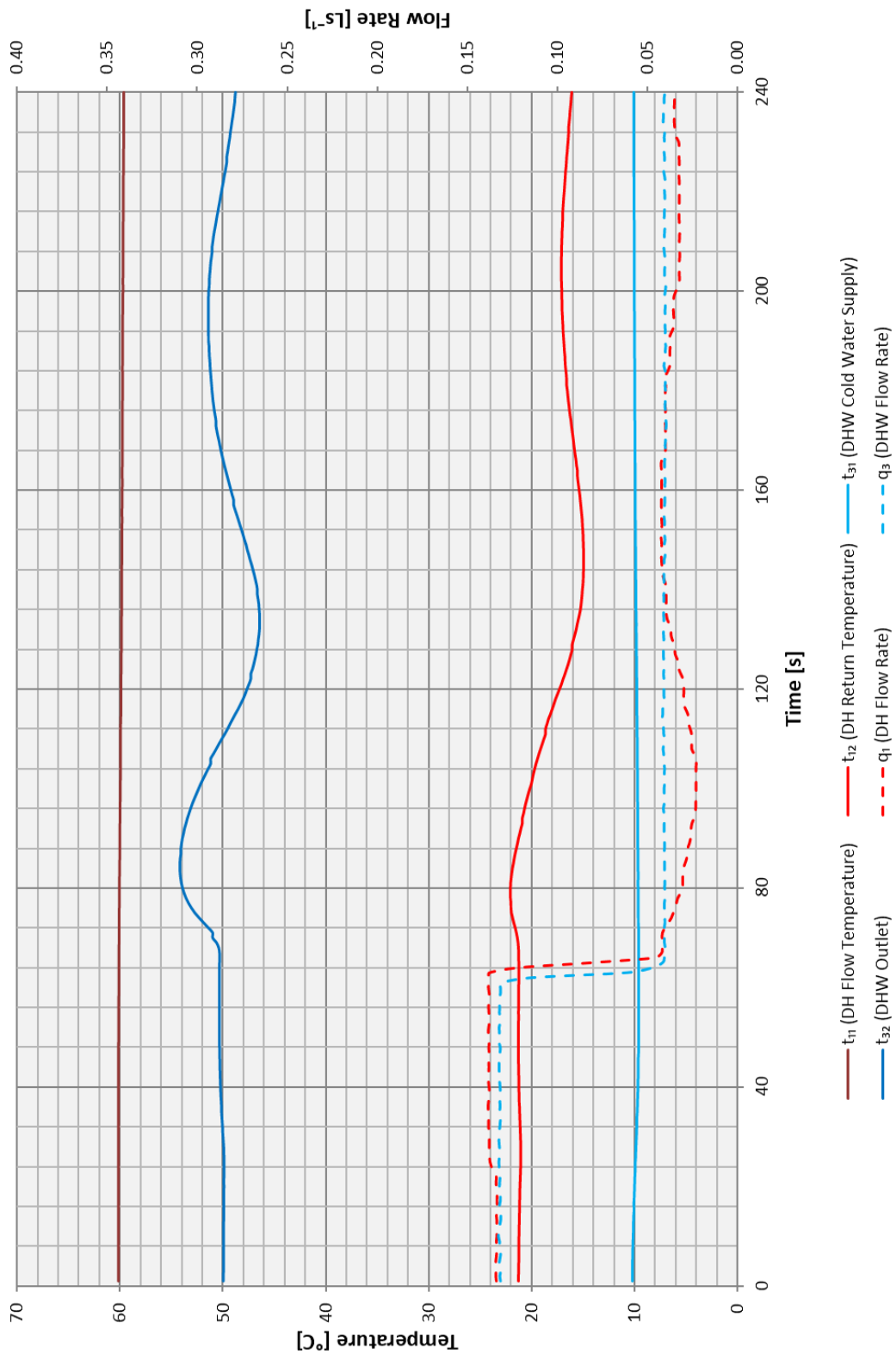

Figure 7.10 - Test 3d – Low Flow DHW at 60 °C

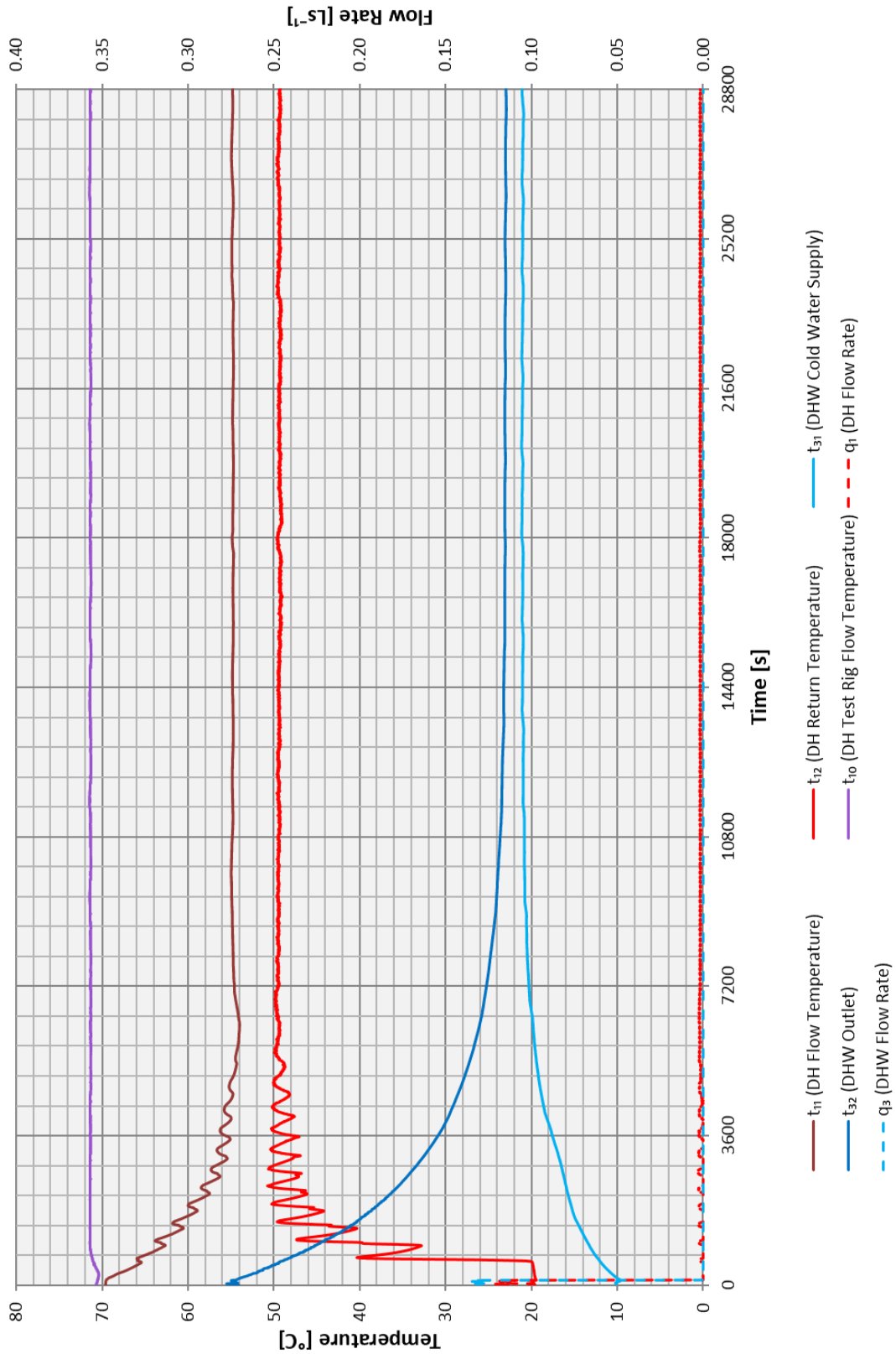

Figure 7.11 - Test 4a – Keep-warm at 70 °C

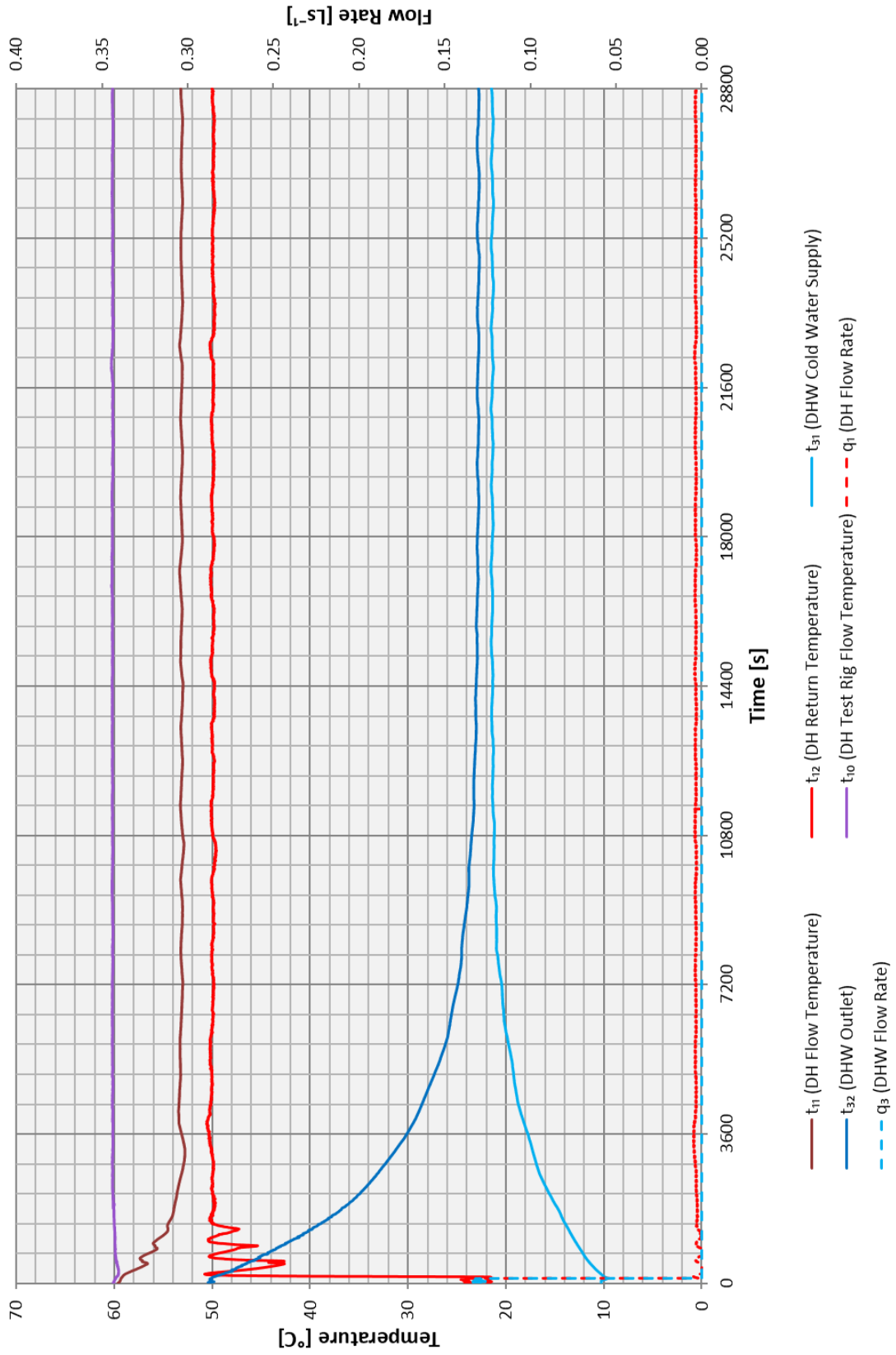

Figure 7.12 - Test 4b – Keep-warm at 60 °C

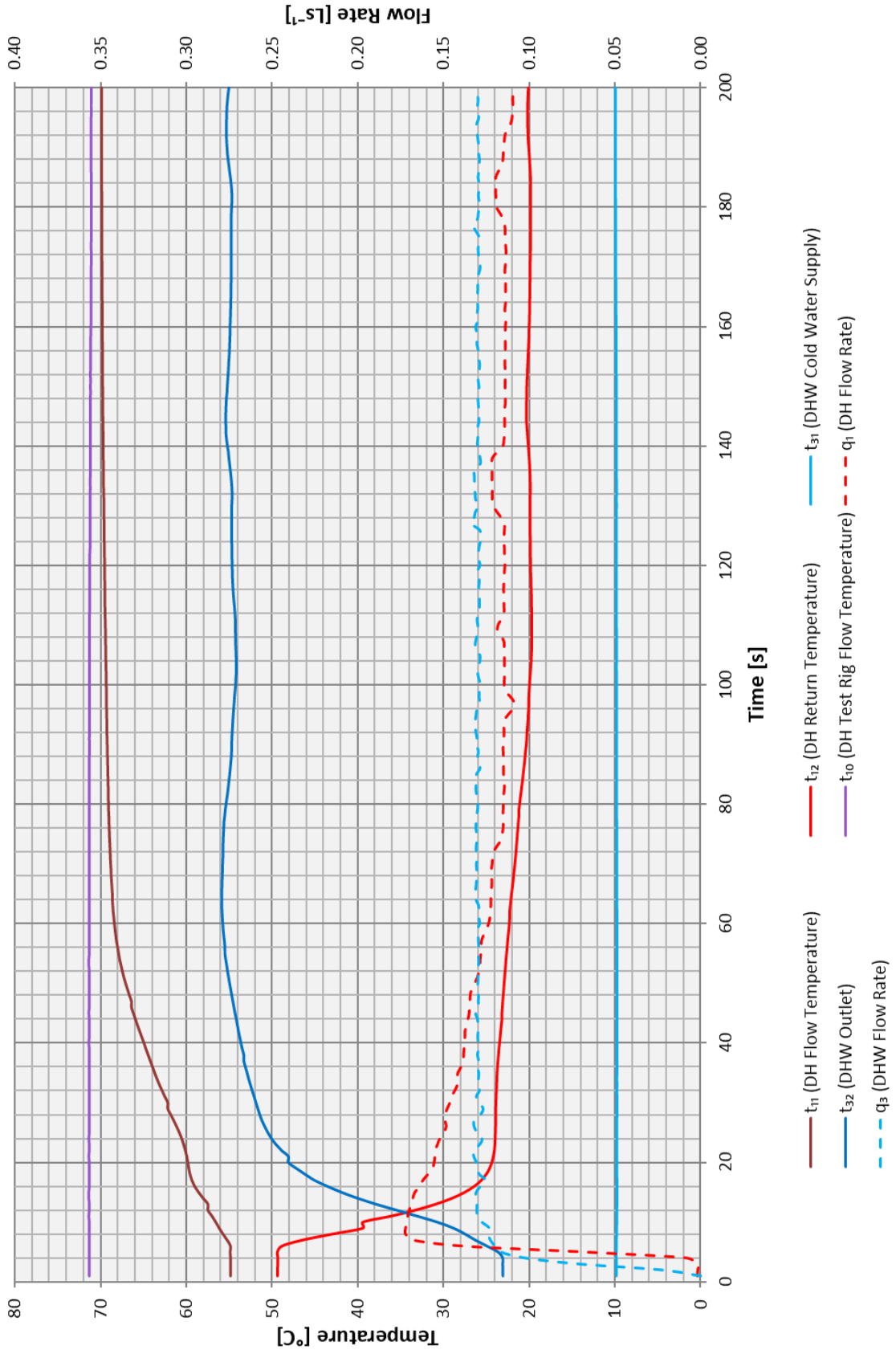

Figure 7.13 - Test 5a – DHW Response Time at 70 °C

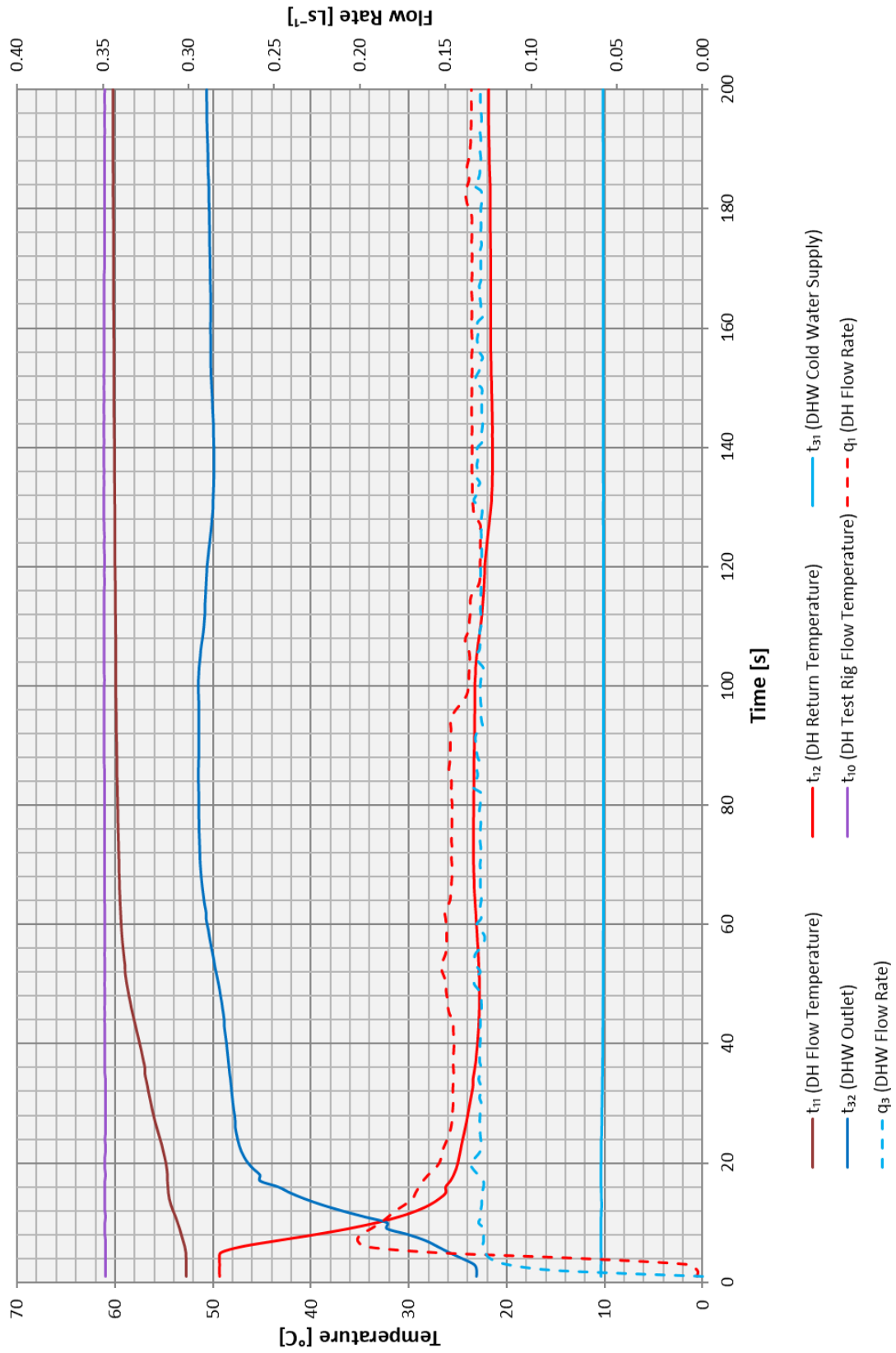

Figure 7.14 - Test 5b – DHW Response Time at 60 °C

7.2 Key Metric and VWARD Summary

7.2.1 The summary tables of the key metrics and VWARDS of the tests described in this report are given in this section.

SUMMARY TABLES START ON NEXT PAGE



Low Temperature VVWART Calculation for Greenstar HIU KE+ with heat meter

Primary flow temperature: 60°C; DHW set point: 50°C; Space heating temperatures: 45°C/35°C

Test carried out by Enertek International for HIGH Temperature BESA Tests

Manufacturer: Worcester Bosch; Model: Greenstar HIU E+ with heat meter; Serial number: 7733600134 ;

VVWART calculation prepared by Ian Williamson of Enertek International on 31 October 2019

	VVWART(°C)	Volume (m ³)
DHW	21	31.6
Standby	50	100.3
Space Heating	36	53.1

Period	VVWART(°C)	% Time
No Heating	43	93%
Heating	37	7%
Overall	42	

	DHW Draw test results		Post DHW Draw (60 seconds)	
	Power (W)	Primary flow (ls)	VVWART (°C)	Primary flow (m ³ /hr)
Low	9246	0.056	20	0.000
Medium	16421	0.102	21	0.000
High	21394	0.134	22	0.000

Standby test results	
Primary flow (Ls ⁻¹)	VVWART (°C)
0.003000	50

	Space Heating test results	
	Power (W)	Primary flow (m ³ /hr)
1kWp	1076	0.011
2kWp	1968	0.020
4kWp	4066	0.040

DHW Draw Volumes pa		
kWh pa	Hours	Volume pa (m ³)
729	75.00	15.10
297	18.00	6.60
444	21.00	9.90

Standby Volumes pa	
Hours	Volume pa (m ³)
8,086	101.10

Space Heating Volumes pa		
kWh pa	Hours	Volume pa (m ³)
98	91.00	3.60
787	400.00	29.40
565	139.00	20.20

Post DHW Draw Volumes pa		
Events pa	Average duration (secs)	Volume pa (m ³)
10000	30	-
660	75	-
300	145	-

Table 7.1 - key metrics of Low Temperature Package



High Temperature VVART Calculation for Greenstar HIU KE+ with heat meter

Primary flow temperature: 70°C; DHW set point: 55°C; Space heating temperatures: 60°C/40°C

Test carried out by Enertek International for HIGH Temperature BESA Tests

Manufacturer: Worcester Bosch; Model: Greenstar HIU Er+ with heat meter; Serial number: 7733600134 ;

VVART calculation prepared by Ian Williamson of Enertek International on 31 October 2019

	VVART(°C)	Volume (m3)
DHW	20	24.5
Standby	49	47.3
Space Heating	44	52.0

	VVART with Keep warm active	% Time
Period	VVART(°C)	% Time
No Heating	39	93%
Heating	44	7%
Overall	40	

	VVART with Keep warm inactive	% Time
Period	VVART	% Time
No Heating	20	93%
Heating	43	7%
Overall	21	

	DHW Draw test results		Post DHW Draw (60 seconds)		
	Power (W)	Primary flow (l/s)	VVART (°C)	Primary flow (m ³ /hr)	VVART (°C)
Low	9859	0.047	19	0.000	16
Medium	18073	0.087	20	0.001	20
High	23206	0.113	21	0.000	20

Standby test results	
Primary flow (Ls ⁻¹)	VVART (°C)
0.002000	49

Space Heating test results		
Power (W)	Primary flow (Ls ⁻¹)	VVART (°C)
1kwp	995	0.010
2kwp	2046	0.020
4kwp	4041	0.041

DHW Draw Volumes pa		
kWh pa	Hours	Volume pa (m ³)
729	69.00	11.70
297	16.00	5.10
444	19.00	7.70

Standby Volumes pa	
Hours	Volume pa (m ³)
8,033	47.30

Space Heating Volumes pa		
kWh pa	Hours	Volume pa (m ³)
98	98.00	3.60
787	385.00	27.90
565	140.00	20.50

Post DHW Draw Volumes pa		
Events pa	Average duration (secs)	Volume pa (m ³)
10000	30	-
660	75	0.01
300	145	-

Table 7.2 - key metrics of High Temperature Package

8 APPENDIX B

8.1 Appliance Documentation

8.1.1 The details of the appliance documentation are given in Table 8.1 below.

Table 8.1 – Documentation Supplied

	Component:	Document Submitted (Y/N):	Manufacturer and type:
1	Space Heating Heat Exchanger	Y	SWEP Heat Exchanger, copper brazed
2	Domestic Hot Water Heat Exchanger	Y	SWEP Heat Exchanger, copper brazed
3	Controller for Space Heating	Y	External programmer (230V), Bosch Sense 2 controller
4	Control Valve and Actuator for Space Heating	Y	ESBE Actuator
5	Space Heating Strainer	N/A	no strainer on space heating circuit
6	Controller for Domestic Hot Water	Y	Braga, control board
7	Control Valve and Actuator for Domestic Hot Water	Y	ESBE Actuator
8	Temperature Sensors	Y	Exa-thermometrics
9	Domestic Hot Water Isolating Valve	Y	Altecnic
10	Primary Side Strainer	Y	Italfim SPA
11	Drain Valves	Y	Orkli
12	Vent Valves	Y	Novasfer
13	Circulation Pump set with AAV & PRV	Y	Grundfos
14	Heat Meter	Y	Sontex 749 Mbus Heat Meter
15	Domestic Hot Water Flow Sensor	Y	Saginomiya
16	Pipes	Y	Bosch, stainless steel
17	Connections	Y	Altecnic
18	Joints	Y	Altecnic
19	Gaskets	Y	Altecnic
20	Expansion Vessel	Y	Zilmet
21	Insulation	Y	Synprodo
22	Pressure Sensors	Y	Wika pressure gauge
A1	'O' Ring	Y	Altecnic
A2	Commissioning guide.	Y	Within Installation Manual
A3	Operation guides with a function description / description of operation and care instructions as suited to the intended user category.	Y	Within Owners Manual
A4	Declaration of Conformity for CE-marked HIUs.	Y	CE mark for current appliances
A5	Full parameter list for electrically controlled HIUs.	Y	Within Installation Manual
A6	Maximum primary static operating differential pressure.	Y	Within Installation Manual
A7	Deactivation procedure of the internal SH pump.	Y	Within Installation Manual
	Model name and type number		Greenstar HIU KE plus with heatmeter
	Serial number		7733600134

8.2 Appliance Components

8.2.1 Details of the main appliance components are given in Table 8.2.

Table 8.2 – Appliance Components details

Greenstar HIU KE Plus with heat meter	
Appliance Serial Number	7733600134
Space Heating Heat Exchanger	SWEP Heat Exchanger, copper brazed
Domestic Hot Water Heat Exchanger	SWEP Heat Exchanger, copper brazed
Controller for Space Heating	External programmer (230V), Bosch Sense 2 controller
Control Valve & Actuator for Space Heating	ESBE Actuator
Controller for Domestic Hot Water	Braga, control board
Temperature Sensors	Exa-thermometrics
Domestic Hot Water Isolating valve	Altecnic
Primary Side Strainer	Italfim SPA
Circulation Pump	Grundfos
Heat Meter	Sontex 749 Mbus Heat Meter
Domestic Hot Water Flow Sensor	Saginomiya
Pipes	Bosch, stainless steel
Connections	Altecnic
`O` Rings	Altecnic
Gaskets	Altecnic
Expansion Vessel	Zilmet
Pressure Sensors	Wika pressure gauge
Insulation	Synprodo

8.3 Appliance Photographs



Figure 8.1 – Photograph of appliance with case off



Figure 8.2 – Photograph of appliance with case on

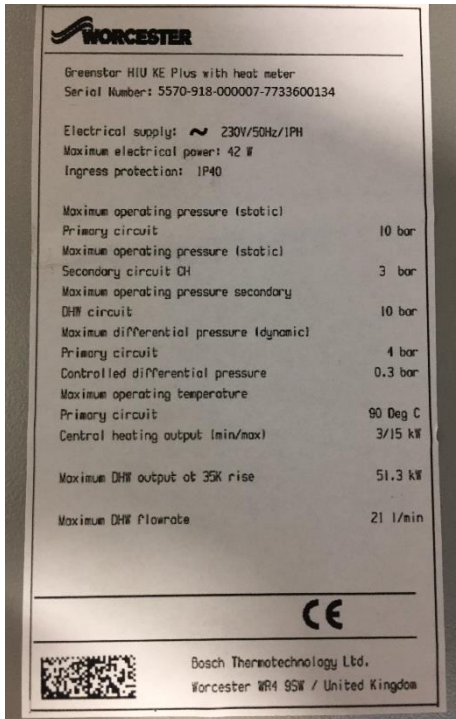

Figure 8-3 – Data Label

8.4 Calibrations and uncertainties

8.4.1 A list of equipment, their calibrations and uncertainties are given in Table 8.3 below.

Table 8.3 - EIL Equipment Calibration and Uncertainties

Equipment Name	ID Number	Calibration Certificate	Measurement Uncertainty $K=2$ $\frac{U}{\sqrt{20}}$	Units	Calibration Date	Calibration Due
Flow Meter [Primary Flow Rate]	FM 601	U99513-19	±0.0004	l/s	26-06-2019	26/06/2020
Flow Meter [DHW Flow Rate]	FM 602	U98515-19	±0.00305	l/s	26-06-2019	26/06/2020
Flow Meter [SH Flow Rate]	FM 603	U98530-19	±0.04871	l/s	27-06-2019	27/06/2020
Flow Meter [DHW Flow Rate]	FM 605	U98539-19	±0.00576	l/s	28-06-2019	28-06-2020
Pressure Transducer [Primary Supply]	PT 086	U98458-19	±6.82	kPa	22-06-2019	22/06/2020
Pressure Transducer [Primary Return]	PT 085	U98460-19	±7.88	kPa	22-06-2019	22/06/2020
Pressure Transducer [DHW Output Pressure]	PT 083	U98469-19	±7.73	kPa	23-06-2019	23/06/2020
Pressure Transducer [DHW Cold Water Supply]	PT 084	U98468-19	±7.31	kPa	23-06-2019	23/06/2020
Pressure Transducer [SH Flow]	PT 087	U98463-19	±7.26	kPa	22-06-2019	22/06/2020
Pressure Transducer [SH Return]	PT 088	U98461-19	±7.30	kPa	22-06-2019	22/06/2020
PRT Probe [Primary Supply Temp]	PRT 4709	EIL 436771	±0.4	°C	31/07/2019	31/07/2020
PRT Probe [Primary Return Temp]	PRT 4708	EIL 436771	±0.4	°C	31/07/2019	31/07/2020
PRT Probe [DHW Output Temp]	PRT 4711	EIL 436772	±0.4	°C	31/07/2019	31/07/2020
PRT Probe [Cold Water Supply Temp]	PRT 4710	EIL 436771	±2.2	°C	31/07/2019	31/07/2020
PRT Probe [SH Supply Temp]	PRT 4707	EIL 436771	±0.4	°C	31/07/2019	31/07/2020
PRT Probe [SH Return Temp]	PRT 4706	EIL 436771	±0.5	°C	31/07/2019	31/07/2020
Pressure Transducer [Static Pressure Test]	PT 090	U100553-19	±50	kPa	21/11/2019	20/11/2020
Software	VERSION – LabVIEW, Version 5, Service pack 1					

Report Issue No	Reason for Report Update
1	Original Issue



1 Malmo Road
Sutton Fields
Kingston upon Hull, HU7 0YF

+44 (0) 1482 877500
enertekinternational.com
Registered in England No. 2262638

